

# **VXA-320 (VXA-3) TAPE DRIVE**

# **PRODUCT MANUAL**

**COPYRIGHT** Copyright 2006 by Tandberg Data. All rights reserved. This item and the information contained herein are the property of Tandberg Data. No part of this document may be reproduced, transmitted, transcribed, stored in a retrieval system, or translated into any language or computer language in any form or by any means, electronic, mechanical, magnetic, optical, chemical, manual, or otherwise, without the express written permission of Tandberg Data ASA, Kjelsåsveien 161, P.O.Box 134 Kjelsås, N-0411 Oslo, Norway.

**DISCLAIMER** Tandberg Data makes no representation or warranties with respect to the contents of this document and specifically disclaims any implied warranties of merchantability or fitness for any particular purpose. Further, Tandberg Data reserves the right to revise this publication without obligation of Tandberg Data to notify any person or organization of such revision or changes.

**TRADEMARK NOTICES** Tandberg Data Tandberg and Exabyte, EZ17, M2, VXA, and VXAtape are registered trademarks; ExaBotics, MammothTape, and SmartClean are trademarks; SupportSuite is a service mark. All other product names are trademarks or registered trademarks of their respective owners.

**PART NUMBER** 433689-01

**Note:** The most current information about this product is available at Tandberg Data's World Wide Web site [www.tandberg.com](http://www.tandberg.com)

**PRODUCT  
WARRANTY  
CAUTION**

The Tandberg VXA-320 (VXA-3) tape drive is warranted to be free from defects in materials, parts, and workmanship, and conforms to the current product specification. For the specific details of your warranty, refer to your sales contract or contact the company from which you purchased the tape drive.

The warranty for the tape drive shall not apply to failures caused by:

- ▶ Physical abuse or use not consistent with the operating instructions or product specifications.
- ▶ Use of any type of data cartridge other than an Tandberg VXAtape or an Tandberg approved VXAtape cartridge.
- ▶ Use of any type of cleaning material other than an Tandberg VXAtape Cleaning Cartridge.
- ▶ Repair or modification by any one other than Tandberg's personnel or agent in a manner differing from the maintenance instructions provided by Tandberg Data.
- ▶ Removal of the Tandberg Data identification label(s).
- ▶ Physical abuse due to improper packaging of returned tape drives.

If problems with the tape drive occur, contact Tandberg Data or your service provider; do not void the product warranty by allowing untrained or unauthorized personnel to attempt repairs.



**Caution**

Returning the tape drive in unauthorized packaging may damage the unit and void the warranty.

If you are returning the tape drive for repair, package it in its original packaging (or in replacement packaging obtained from your vendor).

---

---

**CONTACTING  
TANDBERG DATA**

<b>To obtain general information</b>	
Tandberg Data ASA International Headquarters	Kjelsåsveien 161, P.O.Box 134 Kjelsås, N-0411 Oslo, Norway Tel: +47 22 18 90 90
World Wide Web	<a href="http://www.tandberg.com">www.tandberg.com</a>
<b>To obtain technical support</b>	
Tandberg Data Technical Support	<a href="http://www.tandberg.com">www.tandberg.com</a>
<b>To order supplies and accessories</b>	
Tandberg Data Sales Support	<a href="http://www.tandberg.com">www.tandberg.com</a>
<b>To return equipment for service (RMA Request)</b>	
Tandberg Data Service	<a href="http://www.tandberg.com">www.tandberg.com</a>

## HOW TO USE THIS MANUAL

This manual describes how to install, operate, and maintain the VXA™-320 tape drive. It also provides functional, performance, and environmental specifications.

### ORGANIZATION

The information in this manual is organized into chapters that allow you to quickly locate the information you need.

#### First-time installation

If you are installing the tape drive for the first time, refer to the following chapters:

- ▶ [Chapter 1](#) provides an overview of the tape drive's features and components.
- ▶ [Chapter 2](#) provides instructions for installing the tape drive, connecting it to the host computer, and powering it on.

#### Operation, troubleshooting, maintenance, and service

Refer to these chapters for information about operating, maintaining, and troubleshooting your tape drive:

- ▶ [Chapter 3](#) to learn how to load cartridges, clean the tape drive, and read the LEDs.
- ▶ [Chapter 4](#) provides troubleshooting recommendations.
- ▶ [Chapter 5](#) provides information about service and maintenance for the tape drive, including returning it for service, upgrading firmware, and obtaining a diagnostic listing.

#### Specifications, standards, and terms

These chapters are for engineering, purchasing, or marketing personnel who want to evaluate the tape drive to determine the feasibility of integrating it into their product lines.

- ▶ [Chapter 6](#) provides an overview of the SCSI communication interface and SCSI command protocol supported by the tape drive. It also describes the communication interface specifications for the tape drive, including cable and connector requirements for the LVD SCSI interface.
- ▶ [Chapter 7](#) provides specifications for the tape drive, including performance, reliability, power, and environmental specifications. This chapter also provides safety and regulatory agency standards compliance information.
- ▶ The [Glossary](#) provides definitions of terms used in this book.

## RELATED PUBLICATIONS

For more information about the tape drive and the standards used by the tape drive, refer to the following publications. To order an Tandberg Data publication, see “[Contacting Tandberg Data](#)” on page iv. To download a PDF version of an Tandberg Data publication, visit the Tandberg Data web site [www.tandberg.com](http://www.tandberg.com)

**Note:** The VXA-320 publications are included as PDF files on the CD that accompanies your tape drive.

### VXA-320 Publications

- ▶ *VXA-320 SCSI Tape Drive Quick Start*, 433690-01
- ▶ *VXA-320 (VXA-3) SCSI Reference Manual*, 433691-01

### Standards Publications

- ▶ *Information Technology - SCSI Primary Commands - 2 (SPC-2)*, ANSI INCITS 351-2001
- ▶ *Information Technology – SCSI Parallel Interface-3 (SPI-3)*, ANSI INCITS 336-2000
- ▶ *Information Technology -SCSI Architecture Model - 2 (SAM-2)*, ANSI INCITS 366-2003
- ▶ *Information Technology - SCSI Stream Commands - 2 (SSC-2)*, ANSI INCITS 380-2003
- ▶ *TapeAlert Specification*, NCITS T10/02-142R0, Version 3.0, March 2002

## CONVENTIONS USED IN THIS MANUAL

This manual uses the following conventions:

**Note:** Notes provide additional information or suggestions about the topic or procedure being discussed..

---

**!** **Important** Read text marked by the “Important” icon for information that will help you complete a procedure or avoid extra steps.

---

**Caution**

Read text marked by the “CAUTION” icon for information you must know to avoid damaging the autoloader, tape drive, or losing data.

---

---

**Warning**

Read text marked by the “WARNING” icon for information you must know to avoid personal injury.

---

---

# Contents

<b>How to Use This Manual</b> .....	<b>xiii</b>
<b>1 VXA-320 Features</b> .....	<b>1</b>
Tape Drive Models and Interfaces. ....	1
Components. ....	2
Front Panel Components. ....	2
Back Panel Components – Internal Tape Drive .....	3
Back Panel Components – External Tape Drive .....	4
Tape Drive Labels .....	5
<b>2 Installation</b> .....	<b>7</b>
Unpacking the Tape Drive .....	7
Installing the Tape Drive .....	7
Installing the Internal SCSI Tape Drive .....	8
Installing the External SCSI Tape Drive .....	14
Integrating the Tape Drive .....	18
<b>3 Operation</b> .....	<b>19</b>
Monitoring the LEDs. ....	20
Using VXAtape Cartridges .....	22
Setting the Write-Protect Switch .....	22
Loading a Cartridge .....	22
Unloading a Cartridge .....	22
Storing the Cartridges .....	23
Cleaning the Tape Drive .....	23
Determining When to Clean the Tape Drive .....	23
Using a Cleaning Cartridge .....	24
Resetting the Tape Drive .....	24

<b>4</b>	<b>Troubleshooting</b>	<b>25</b>
	Resolving Common Problems	25
	Tape Drive Will Not Accept a Cartridge	25
	LED 4 is Flashing Orange	26
	Tape Drive Will Not Eject a Cartridge	27
	Tape Drive is not Detected by the Operating System or Backup Application	27
	A Service Notification LED Code Appears	28
	Backup Application is Reporting an Error	29
	Troubleshooting with VXATool	31
	Getting Started (Important First Step)	31
	Performing a Write/Read Test	31
	Updating Firmware	31
	Capturing a Diagnostic Log	31
	Gathering Troubleshooting Information for Technical Support	32
	VXA-320 Tape Drive Information	32
	SCSI Bus Information	32
	Operating System Information	33
	Backup Application Information	33
	Tape Drive Diagnostic Information	33
<b>5</b>	<b>Service and Maintenance</b>	<b>35</b>
	Returning the Tape Drive for Service	35
	Upgrading Firmware	36
	Obtaining a Diagnostic Listing	36
<b>6</b>	<b>Communication Interface and Command Protocol</b>	<b>37</b>
	Communication Interface versus Command Protocol	37
	SCSI Communication Interface	38
	SCSI Bus Phases	38
	SCSI Message System	39
	SCSI Interface Requirements	40
	Internal Tape Drive	41
	External Tape Drive	43
	SCSI Command Protocol	44
	Command Set	44
	Status Bytes	46
	Sense Keys	46

<b>7 Specifications</b>	<b>49</b>
Data Capacities	49
Performance Specifications	50
Data Transfer Rates	50
Read and Write Specifications	50
Tape Speed and Access Time	51
Reliability Specifications	51
Size and Weight	52
Power Specifications	53
Internal Tape Drive	53
External Tape Drive	54
Acoustic Noise	55
Environmental Specifications	56
Environmental Conditions for the Tape Drive	56
Environmental Conditions for the VXAtape Cartridges	60
Packaging and Shipping Specifications	61
Shipping Cartons	61
Packaging Materials	62
Safety and Regulatory Compliance	62
Underwriters Laboratory	62
TUV Product Service	62
United States: FCC Declaration of Conformity	63
Canadian Verification	63
European Community	64
Japan	64
Australia and New Zealand	64
Taiwan	64
Restriction of Hazardous Substances in Electrical and Electronic Equipment (RoHS)	64
Waste of Electronic and Electrical Equipment (WEEE)	64
<b>Glossary</b>	<b>65</b>
<b>Index</b>	<b>71</b>

# NOTES

# Figures

## 1 VXA-320 Features

<b>Figure 1-1</b>	VXA-320 tape drives (internal and external models) . . . . .	1
<b>Figure 1-2</b>	Internal tape drive: front-panel components. . . . .	2
<b>Figure 1-3</b>	External tape drive: front-panel components . . . . .	2
<b>Figure 1-4</b>	Internal tape drive: back-panel components. . . . .	3
<b>Figure 1-5</b>	External tape drive: back-panel components . . . . .	4
<b>Figure 1-6</b>	Top-panel label (SCSI tape drive) . . . . .	5
<b>Figure 1-7</b>	Back-panel label (SCSI tape drive) . . . . .	5

## 2 Installation

<b>Figure 2-1</b>	Internal SCSI tape drive: back-panel components. . . . .	8
<b>Figure 2-2</b>	SCSI ID settings . . . . .	10
<b>Figure 2-3</b>	Connecting the SCSI cable and power cable (another device is the last device on the bus) . . . . .	11
<b>Figure 2-4</b>	Connecting a SCSI cable (tape drive is last device on the bus). . .	12
<b>Figure 2-5</b>	Screw mounting configurations (internal model) . . . . .	13
<b>Figure 2-6</b>	External SCSI tape drive: back-panel components . . . . .	14
<b>Figure 2-7</b>	Terminating the SCSI bus (external model) . . . . .	16

## 3 Operation

<b>Figure 3-1</b>	Internal tape drive: front-panel components. . . . .	19
<b>Figure 3-2</b>	External tape drive: front-panel components . . . . .	19
<b>Figure 3-3</b>	Setting the write-protect switch . . . . .	22

## 7 Specifications

<b>Figure 7-1</b>	Physical dimensions of the internal tape drive. . . . .	52
<b>Figure 7-2</b>	Physical dimensions of the external tape drive . . . . .	53
<b>Figure 7-3</b>	Internal model: Operating temperature and humidity ranges . . .	57
<b>Figure 7-4</b>	External model: Ambient operating temperature and humidity ranges	58

# NOTES

# Tables

## 3 Operation

<b>Table 3-1</b>	LED states . . . . .	20
------------------	----------------------	----

## 4 Troubleshooting

<b>Table 4-1</b>	Service Notification error recovery procedures . . . . .	28
------------------	--	----

## 6 Communication Interface and Command Protocol

<b>Table 6-1</b>	SCSI bus phases and information transfer phases . . . . .	38
<b>Table 6-2</b>	SCSI messages supported by the tape drive . . . . .	39
<b>Table 6-3</b>	SCSI cable and connector specifications . . . . .	41
<b>Table 6-4</b>	Pin assignments for the wide LVD connector . . . . .	42
<b>Table 6-5</b>	SCSI cable requirements . . . . .	43
<b>Table 6-6</b>	SCSI command set . . . . .	44
<b>Table 6-7</b>	Status byte descriptions . . . . .	46
<b>Table 6-8</b>	Supported sense keys . . . . .	46

## 7 Specifications

<b>Table 7-1</b>	Data capacities in gigabytes (GB) . . . . .	49
<b>Table 7-2</b>	Data transfer rates in megabytes per second . . . . .	50
<b>Table 7-3</b>	Read and write specifications . . . . .	50
<b>Table 7-4</b>	Tape speed and access times . . . . .	51
<b>Table 7-5</b>	Reliability specifications . . . . .	51
<b>Table 7-6</b>	Size and weight . . . . .	52
<b>Table 7-7</b>	Pin assignments for the power connector . . . . .	53
<b>Table 7-8</b>	Power specifications (internal model) . . . . .	54
<b>Table 7-9</b>	Power consumption (internal model) . . . . .	54
<b>Table 7-10</b>	Power supply specifications (external model) . . . . .	55
<b>Table 7-11</b>	Power consumption (external model) . . . . .	55
<b>Table 7-12</b>	Acoustic noise specifications (internal tape drive) . . . . .	55
<b>Table 7-13</b>	Acoustic noise specifications (external tape drive) . . . . .	55
<b>Table 7-14</b>	Temperature and humidity specifications for the tape drive . . . . .	56
<b>Table 7-15</b>	Internal model: Operating temperature and humidity points . . . . .	57
<b>Table 7-16</b>	External model: Operating temperature and humidity points . . . . .	58
<b>Table 7-17</b>	Particulate contamination limits . . . . .	59
<b>Table 7-18</b>	Shock specifications . . . . .	59
<b>Table 7-19</b>	Vibration specifications . . . . .	60
<b>Table 7-20</b>	Temperature and humidity specifications for the VXA tape cartridges . . . . .	60
<b>Table 7-21</b>	Shipping carton weights and dimensions . . . . .	61

# NOTES

## 1

## FEATURES

This chapter describes the VXA-320 tape drive features and components. The VXA-320 tape drive is designed for the storage and management of enterprise-wide, mission-critical data.

The VXA-320 tape drive's capabilities are:

Data storage	160 gigabytes (GB) of uncompressed (native) data on a 230-meter VXAtape
Data transfer rate	12 megabytes (MB) per second (native) and is read/write compatible with the second-generation VXA tape drive (VXA-2)

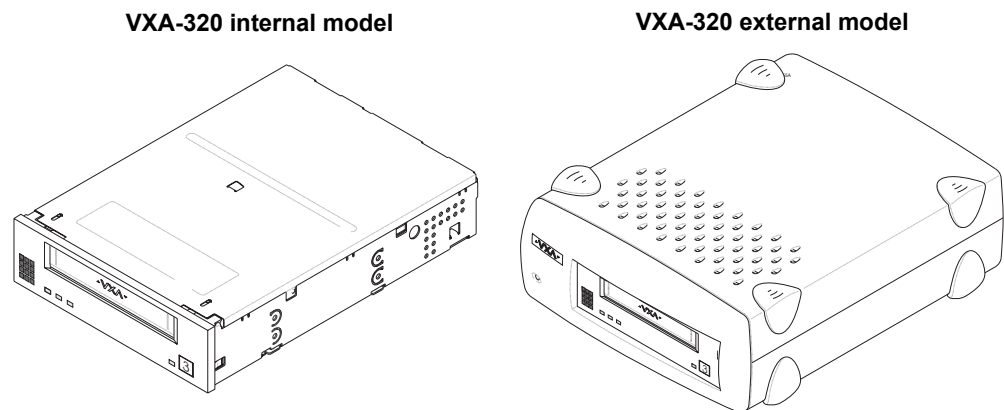

**Figure 1-1** VXA-320 tape drives (internal and external models)

## TAPE DRIVE MODELS AND INTERFACES

For simple and convenient system integration, the VXA-320 tape drive is available in external and internal models. The internal VXA-320 complies with industry standard 5.25-inch half-high form factor mounting requirements and can be mounted horizontally or vertically. The external standalone model is housed in an enclosure that allows the device to be placed horizontally or vertically on a flat surface. External models can also be stacked. Neither model can be operated upside down.

Both the internal and external models of the VXA-320 tape drive are available with a wide, High-density (HD), 68-pin low-voltage differential (LVD) SCSI interface.

## COMPONENTS

This section describes the major components of both the internal and external models of the tape drive.

### FRONT PANEL COMPONENTS

Figure 1-2 and Figure 1-3 show the controls and indicators on the front panel of the tape drive. For more information about using these controls and indicators, see Chapter 3.

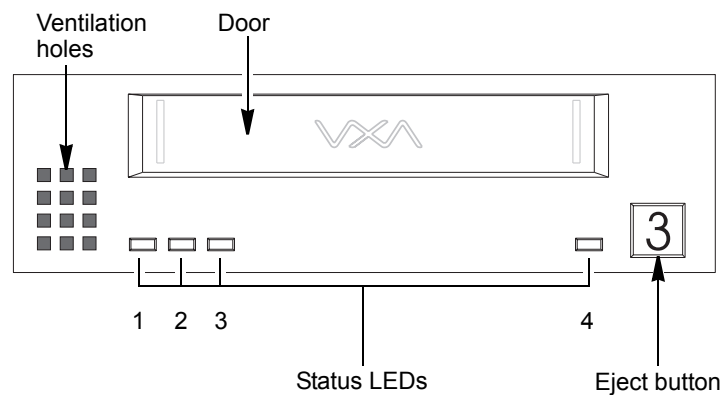

**Figure 1-2** Internal tape drive: front-panel components

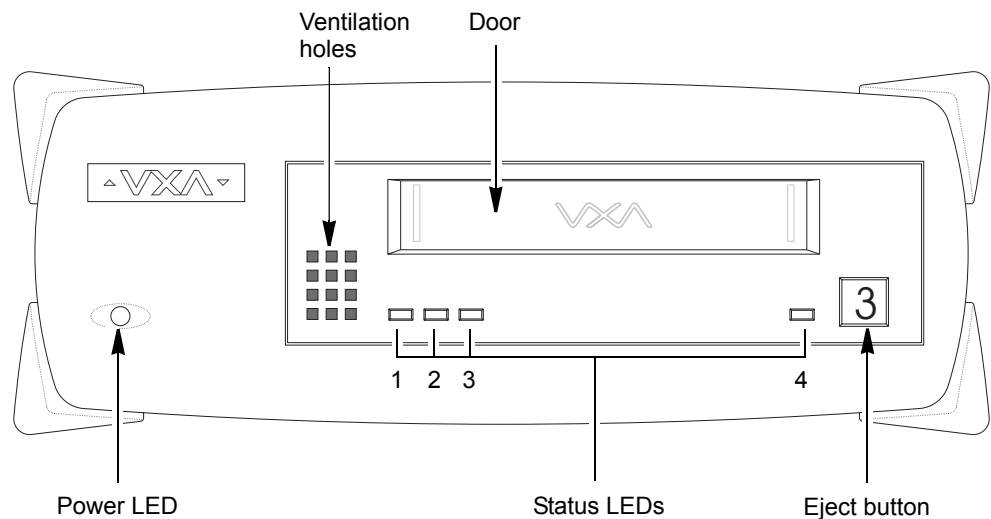

**Figure 1-3** External tape drive: front-panel components

**Door** Used for inserting the cartridge into the tape drive.

**Eject Button** Used to unload the tape and eject the cartridge.

**Status LEDs (Light Emitting Diodes)** Show status information, which is described in “Monitoring the LEDs” on page 20.

**Power LED** Shows the power-on status of the external tape drive.

## BACK PANEL COMPONENTS – INTERNAL TAPE DRIVE

Figure 1-4 shows the back panel components of the internal SCSI tape drive. For more information about using these components during installation, see Chapter 2.

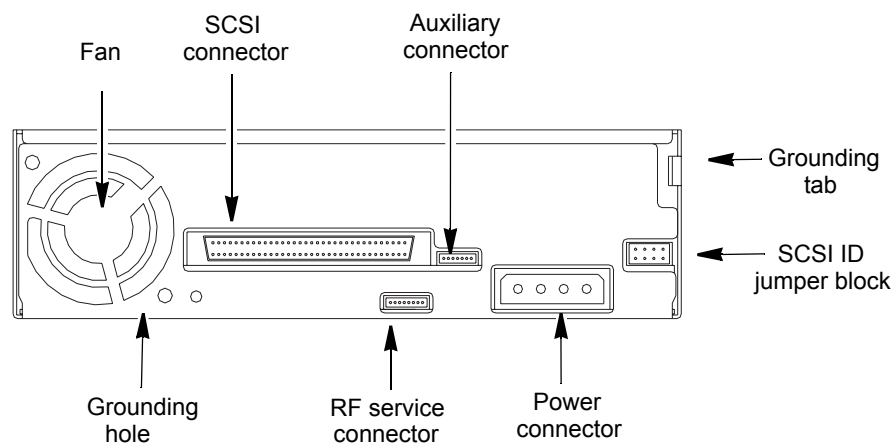

**Figure 1-4** Internal tape drive: back-panel components

**Fan** Provides cooling to maintain proper operating temperature at the tape path.

**SCSI Connector** Used to connect the tape drive to the SCSI bus. This is a 68-pin LVD SCSI connector. (See Table 6-4 for pin assignments.)

**Auxiliary Connector** Used for tape drive diagnostics.

**SCSI ID Jumper Block (SCSI model only)** Used to set the SCSI ID.

**Grounding Tab and Hole** Used to provide additional chassis grounding. (The mounting screws also provide grounding for the tape drive.)

**RF Service Connector** Reserved for Tandberg Data Service personnel.

**Power Connector** Used to connect a power cable from the enclosure’s power supply. This is a 4-pin connector. (See Table 6-4 for pin assignments.)

## BACK PANEL COMPONENTS – EXTERNAL TAPE DRIVE

Figure 1-5 shows the back-panel components of the external SCSI model of the tape drive.

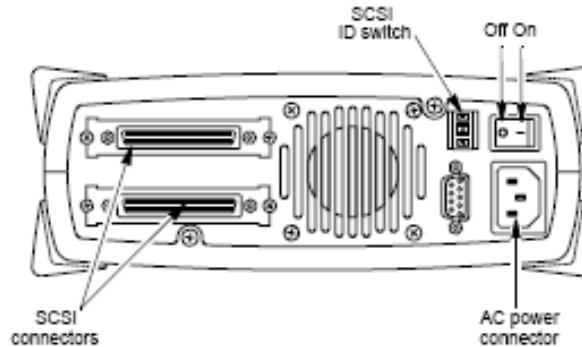

**Figure 1-5** External tape drive: back-panel components

**On/Off Switch** Used to turn power on and off.

**AC Power Connector** Used to provide power through a grounded AC power connector. A power cord is included with the tape drive.

**Serial Connector** Used to connect the tape drive to the serial port of a computer for performing diagnostic operations with VXATool (see [page 31](#)).

**SCSI Connectors (SCSI tape drive only)** Used to connect the tape drive to the SCSI bus with two SCSI cables or one SCSI cable and a terminator. These connectors are 68-pin high-density LVD SCSI connectors.

**SCSI ID Switch** Used to set the SCSI ID.

## TAPE DRIVE LABELS

The VXA-320 tape drive includes two labels:

- ▶ The top-panel label (Figure 1-6) shows the tape drive’s part number, serial number, revision, connector type, and agency information.
- ▶ The back-panel label (Figure 1-7) identifies the tape drive connectors and jumpers.

Depending on the model tape drive you have, the labels on your tape drive may differ.



**Caution**

Do not remove or modify these labels. If you do so, you will void the product warranty.

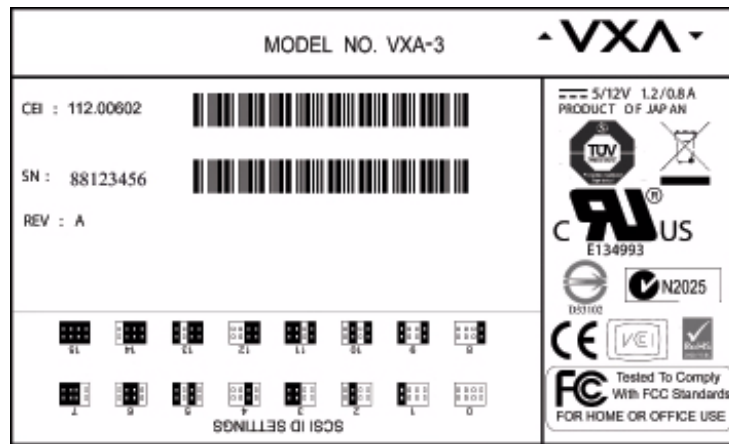

Figure 1-6 Top-panel label (SCSI tape drive)

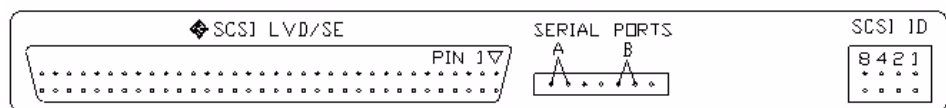

Figure 1-7 Back-panel label (SCSI tape drive)

## NOTES

# 2

## INSTALLATION

This chapter provides step-by-step instructions for installing the internal and external models of the VXA-320 tape drive. The information in this chapter expands on the instructions in the *Quick Start* guide that accompanied your tape drive.

### UNPACKING THE TAPE DRIVE

All Tandberg Data tape drives are tested, inspected, and carefully packaged at the factory. However, because shipping damage can occur, you should follow the steps below to unpack the tape drive:

1. Visually inspect the shipping container and notify your freight carrier immediately if you see any damage.
2. Place the shipping container on a flat, clean, stable surface. If parts are missing or the equipment is damaged, notify your supplier or Tandberg Data.
3. Save the original shipping container and packaging materials in case you need to reship the tape drive.

### INSTALLING THE TAPE DRIVE

The installation instructions for your tape drive depend on what model you have:

- ▶ To install the internal LVD SCSI model of the tape drive, read [“Installing the Internal SCSI Tape Drive,” beginning on page 8.](#)
- ▶ To install the external LVD SCSI model of the tape drive, read [“Installing the External SCSI Tape Drive,” beginning on page 14.](#)

## INSTALLING THE INTERNAL SCSI TAPE DRIVE

The internal tape drive complies with industry-standard, 5.25-inch half-high form factor mounting requirements and can be mounted either horizontally or vertically, but not upside down.

When installing the tape drive, refer to [Figure 2-1](#) for the location of the back-panel components on the SCSI tape drive.

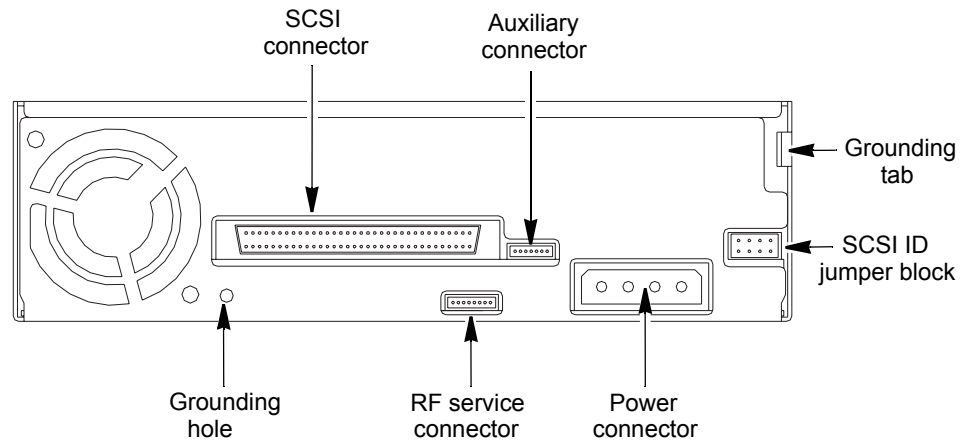

**Figure 2-1** Internal SCSI tape drive: back-panel components

### Before You Begin

Before you begin hardware installation, do the following:

1. **Select a suitable location for your tape drive**—Ensure that the work area is free from conditions that could cause electrostatic discharge (ESD). Discharge static electricity from your body by touching a known grounded surface, such as your computer's metal chassis.
2. **Install an LVD SCSI host bus adapter** — Install the LVD SCSI host bus adapter (HBA) and any necessary drivers in the host computer.

3. **Select your backup software application** — To obtain information about which backup software applications work with the tape drive, visit Tandberg Data's web site [www.tandberg.com](http://www.tandberg.com). You can install the backup software application on the host computer before or after you install the tape drive. However, if you install the backup application software first, you may need to reconfigure it for use with the tape drive.

---

**! Important** Do not connect the tape drive to a RAID controller. The tape drive will not operate properly if it is connected to a RAID controller.

Although the tape drive's High-density LVD SCSI interface is compatible with both single-ended and narrow SCSI buses, to avoid performance issues Tandberg Data does not recommend using the tape drive on either of these buses.

If any single-ended device, including a single-ended terminator is attached to the LVD bus, the result is that all devices on that bus will run in single-ended mode. Tandberg Data recommends that you do not use the tape drive on a bus with a single-ended device.

---



### Caution

Do not connect the tape drive to an HVD controller. Doing so may damage the tape drive.

---

4. **Obtain the necessary cables and terminator** — The tape drive connects to the SCSI bus using a cable with a high-density, 68-pin male connector. This cable must meet the guidelines in “[SCSI Cable Requirements](#),” beginning on page 41. If the tape drive is the last device on the SCSI bus, you will need to install an LVD/SE terminator at the physical end of the bus.
5. **Do not exceed SCSI bus length restrictions**— The maximum allowable length of an LVD SCSI bus is 12 meters (39 feet) if you have more than two devices on the bus. Make sure the SCSI bus attached to the tape drive does not exceed this length. To determine the length of the bus:
  - a. Add together the lengths of all external SCSI cables attaching devices on the bus. External devices are those connected outside of the server's enclosure.
  - b. Add together the lengths of all SCSI cables attaching internal devices on the bus. Internal devices are those installed within the server's enclosure.
  - c. Add together the lengths of all internal cabling for all other SCSI devices on the bus. Refer to the individual product documentation for cable length information.

### Set the SCSI ID and connect the SCSI cable

1. Power down the computer system.

Turn off all devices attached to the computer in which you plan to install the tape drive, then turn off the computer. Disconnect all power cables.

2. Prepare the drive bay.

Remove the drive bay's cover plate according to the system manufacturer's instructions.

3. Set the SCSI ID jumpers, if necessary.

- a. The tape drive is shipped with a SCSI ID of 11. If another device on the SCSI bus is already configured with this SCSI ID, you will need to change the tape drive's SCSI ID. Reposition the jumpers on the jumper block, as shown in [Figure 2-2](#), to select the desired ID. (If necessary, use flat-nose pliers to remove the jumpers.) If you need an additional jumper, use a 2 mm jumper.

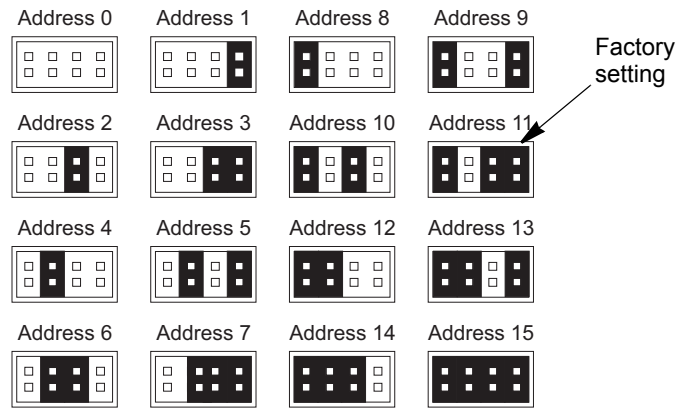

**Figure 2-2** SCSI ID settings

Alternatively, you can remove the jumpers and connect a cable (not included) from a remote switch to the jumper block, then use the remote switch to set the SCSI ID. The cable should use a connector equivalent to Hirose Housing part number DF11-8DS-2C, 2.0MM 8CKT to connect to the jumper block.

---

**! Important** Each device on the SCSI bus must have a unique SCSI ID.

---

b. Provide additional grounding, if desired.

Attaching the tape drive to the enclosure protects the tape drive from ESD. However, if you want additional chassis grounding for the tape drive, use the grounding hole or grounding tab on the back panel (see [Figure 2-1](#)):

- ▶ Connect an M3 (0.25 in.) female spade connector from the host to the tape drive's grounding tab.  
or  
Use an M3 × 0.5 mm × 5 mm machine screw to connect a grounding wire to the grounding hole.

**Caution**

Do not use a screw other than the type specified for attaching the grounding wire, or you may damage the internal components. Screw length must not exceed 5mm.

4. Connect the SCSI cable.
  - a. Check the connector to ensure that no pins are bent or pushed in before connecting it to the tape drive.

**Caution**

To avoid damaging the tape drive, make certain you connect pin 1 on the cable to pin 1 on the tape drive. Pin 1 is on the right, top row of the connector pins (see [Figure 2-3](#)).

- b. Connect one of the enclosure's internal SCSI cables to the SCSI connector on the back of the tape drive (see [Figure 2-3](#)). This cable must meet the guidelines in "SCSI Cable Requirements," beginning on page 41.

**Note:** If desired, you can mount the tape drive (see [page 12](#)) before you connect the SCSI cable, the terminator (if required), and the power cable to the back. However, if the cables are difficult to access in the enclosure, you should extend the cables out through the drive bay and connect them before mounting the tape drive.

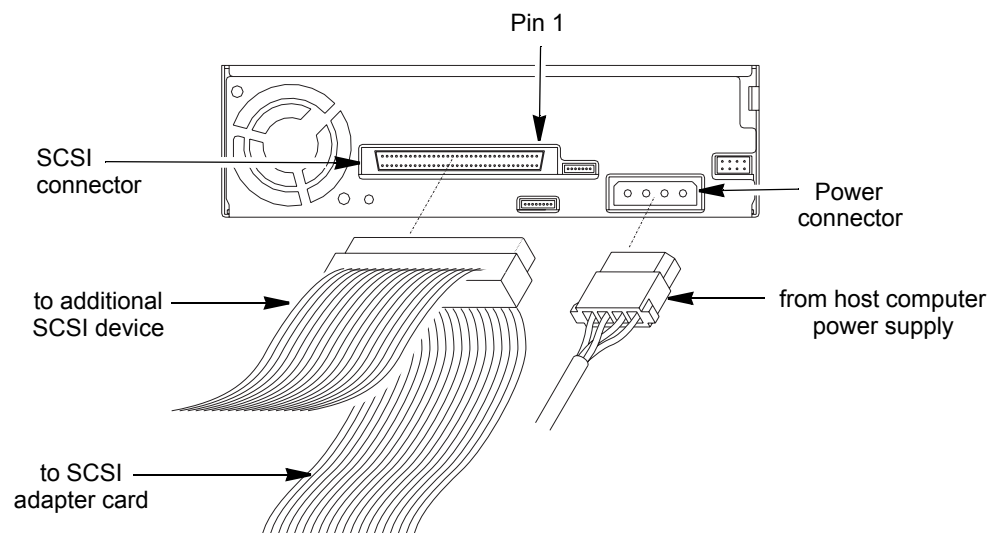
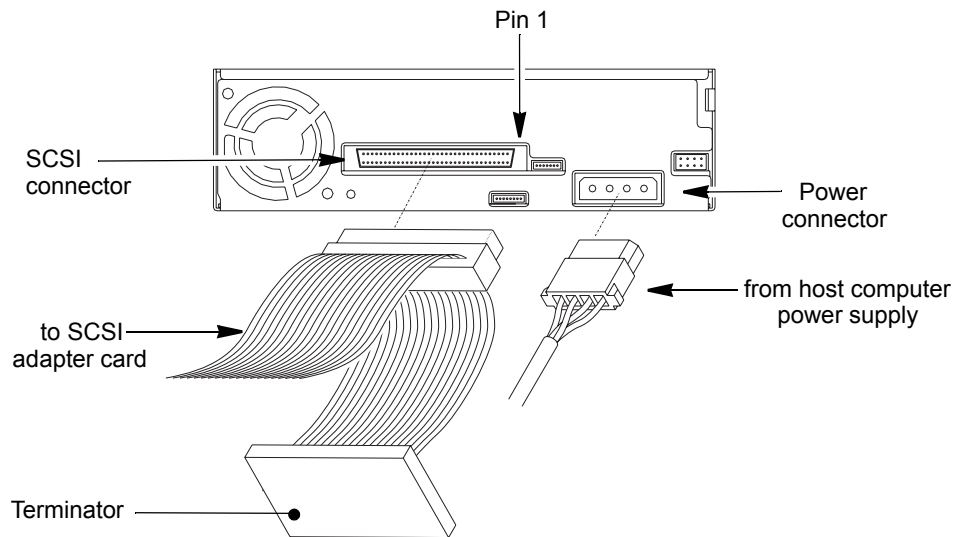

**Figure 2-3** Connecting the SCSI cable and power cable (another device is the last device on the bus)

5. Install an LVD or LVD/SE multimode terminator at the physical end of the SCSI bus. If the cable provided with your adapter has a built-in terminator, do not add another terminator to the bus.

**Note:** If the tape drive is the last device on the SCSI bus and if the SCSI cable has an unused connector at the end, you can terminate the bus there, as shown in [Figure 2-4](#). Alternatively, you can terminate the bus by installing a pass-through terminator on the tape drive's SCSI connector.

If there are additional devices on the SCSI bus, ensure that only the device at the physical end of the bus is terminated.



**Figure 2-4** Connecting a SCSI cable (tape drive is last device on the bus)

## Connect the power cable and mount the tape drive in the enclosure

1. Connect the power cable.

Locate the enclosure's internal power cable and connect it to the tape drive's power connector, as shown in [Figure 2-3](#) or [Figure 2-4](#). The enclosure's power cable connector must be an AMP 1-480424-0 series, or equivalent.

For the pin assignments of the tape drive's power connector, see [Table 7-7 on page 53](#).

2. Mount the tape drive in the drive bay.

Slide the tape drive into the bay. Ensure that no cables are caught or crimped between the tape drive and the chassis. Also ensure that the ventilation fan on the back of the tape drive is not obstructed.

Using the screws provided with the tape drive, secure the tape drive in the drive bay using one of the screw mounting combinations (see [Figure 2-5](#)).



### Caution

To avoid damaging the tape drive, follow these precautions:

- ▶ Use only the M3 × 0.5 × 5 mm Phillips screws. Screw length must not exceed 5mm.
- ▶ Ensure that the chassis is not distorted. (Alignment to the horizontal or vertical plane should not exceed  $\pm 10^\circ$ .)
- ▶ Ensure that no objects (screw heads, cables, or adjacent devices) are pressing against the frame.
- ▶ Do not use a combination of the two sets of mounting holes.
- ▶ Do not obstruct the ventilation fan on the back of the tape drive.

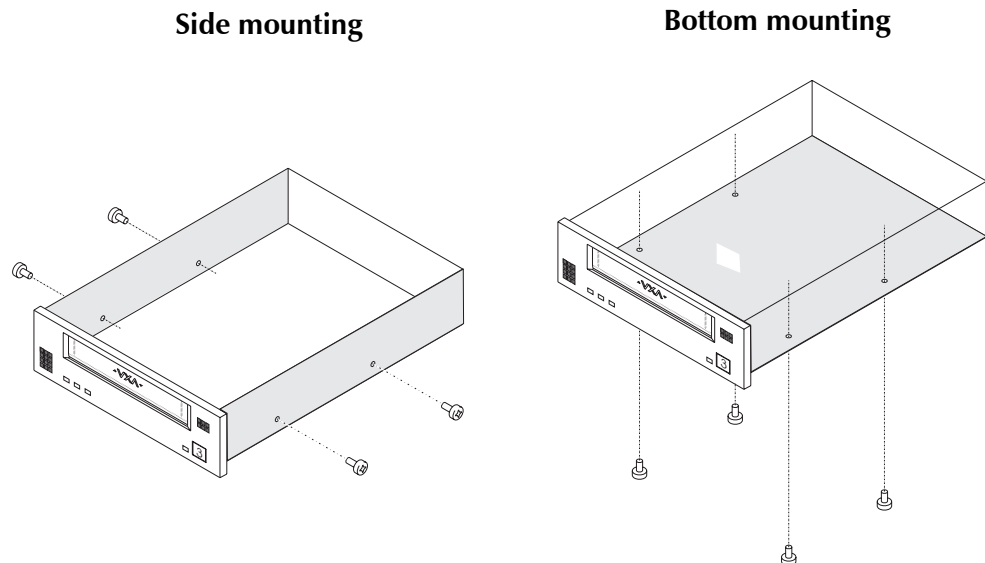

**Figure 2-5** Screw mounting configurations (internal model)

### 3. Power on the computer system or enclosure.

During the tape drive's power-on self-test, the LEDs scroll sequentially right to left, then left to right in amber and green. LED 4 illuminates in red and green. When POST is complete, LED 4 illuminates in green. (See [Table 3-1, "LED states,"](#) on page 20 for a description of the LED states.)

## INSTALLING THE EXTERNAL SCSI TAPE DRIVE

When installing the external SCSI tape drive, refer to [Figure 2-6](#) for the location of the back-panel components.

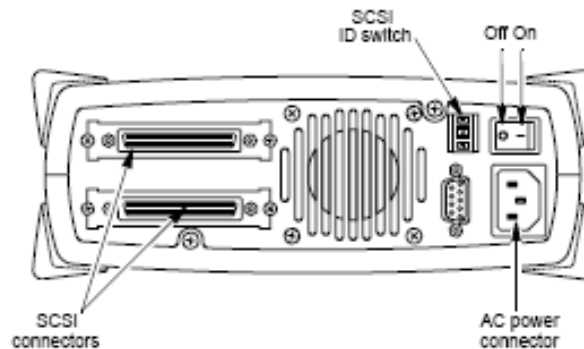

**Figure 2-6** External SCSI tape drive: back-panel components

### Before You Begin

Before you begin hardware installation, do the following:

1. **Select a suitable location for your tape drive**—Ensure that the work area is free from conditions that could cause electrostatic discharge (ESD). Discharge static electricity from your body by touching a known grounded surface, such as your computer’s metal chassis.
2. **Install an LVD SCSI host bus adapter** — Install the LVD SCSI host bus adapter (HBA) and any necessary drivers in the host computer.
3. **Select your backup software application** — To obtain information about which backup software applications work with the tape drive, visit Tandberg Data’s web site [www.tandberg.com](http://www.tandberg.com) You can install the backup software application on the host computer before or after you install the tape drive. However, if you install the backup software application first, you may need to reconfigure it for use with the tape drive.

---

**! Important** Do not connect the tape drive to a RAID controller. The tape drive will not operate properly if it is connected to a RAID controller.

Although the tape drive’s High-density LVD SCSI interface is compatible with both single-ended and narrow SCSI buses, to avoid performance issues Tandberg Data does not recommend using the tape drive on either of these buses.

If any single-ended device, including a single-ended terminator is attached to the LVD bus, the result is that all devices on that bus will run in single-ended mode. Tandberg Data recommends that you do not use the tape drive on a bus with a single-ended device.

---

4. **Obtain the necessary cables and terminator** — The tape drive connects to the SCSI bus using a cable with a high-density, 68-pin male connector. This cable must meet the guidelines in “[SCSI Cable Requirements](#),” beginning on page 41. If the tape drive is the last device on the SCSI bus, you will need to install an LVD/SE terminator at the physical end of the bus.
5. **Do not exceed SCSI bus length restrictions**— The maximum allowable length of an LVD SCSI bus is 12 meters (39 feet) if you have more than two devices on the bus. Make sure the SCSI bus attached to the tape drive does not exceed this length. To determine the length of the bus:
  - a. Add together the lengths of all external SCSI cables attaching devices on the bus. External devices are those connected outside of the server’s enclosure.
  - b. Add together the lengths of all SCSI cables attaching internal devices on the bus. Internal devices are those installed within the server’s enclosure.
  - c. Add together the lengths of all internal cabling for all other SCSI devices on the bus. Refer to the individual product documentation for cable length information.
6. **Make sure the SCSI bus is properly terminated**— You must install an LVD or LVD/SE multimode terminator on the device at the physical end of the SCSI bus. If the tape drive is at the physical end of the SCSI bus, you must install the required terminator on one of the tape drive’s SCSI connectors.

If there are additional devices on the SCSI bus, ensure that only the device at the physical end of the bus is terminated.

### Install the Tape Drive

1. Power down the host computer system.

Turn off all devices attached to the computer to which you plan to connect the tape drive, then turn off the computer. Disconnect all power cables.

2. Set the SCSI ID.

The tape drive is shipped with a SCSI ID of 11. If another device on the SCSI bus is already configured with this SCSI ID, you will need to change the tape drive’s SCSI ID. To change the default ID, press the + and – tabs above and below the SCSI ID indicator until the desired SCSI ID appears. See [Figure 2-6](#).

3. Connect the SCSI cable.
  - a. Ensure that the cable complies with the SCSI-3 specification and has a 68-pin high-density male connector. See [Table 6-5](#) for cable specifications.



#### Caution

Do not use a noncompliant SCSI cable; it will degrade VXA-320 performance and can cause random, nonreproducible errors. See [Table 6-5](#) for cable specifications.

- b. Check the connector to ensure that no pins are bent or pushed in before connecting it to the tape drive.
  - c. Connect a SCSI cable from the host computer system to the back of the tape drive.
  - d. Use the two thumb screws on the cable to fully seat the connector.
4. Install an LVD or LVD/SE multimode terminator at the physical end of the SCSI bus. If the cable provided with your adapter has a built-in terminator, do not add another terminator to the bus.

If the tape drive is the last device on the bus, install a terminator on the unused SCSI connector, as shown in [Figure 2-7](#).

If there are additional devices on the SCSI bus, ensure that only the device at the physical end of the bus is terminated.

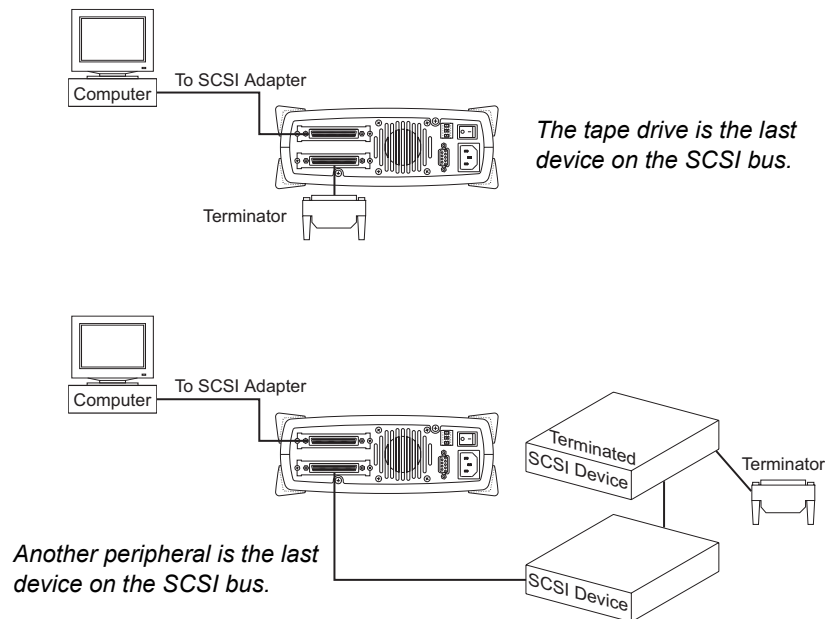

**Figure 2-7** Terminating the SCSI bus (external model)

5. Connect the power cable and turn on the power.

Connect the power cable to the back of the tape drive. Turn on the tape drive's power switch. During the tape drive's power-on self-test (POST), the LEDs scroll sequentially right to left, then left to right in amber and green. LED 4 illuminates in red and green. When POST is complete, LED 4 illuminates in green. (See [Table 3-1, "LED states,"](#) on page 20 for a description of the LED states.)

6. Power on the host computer system.

## Checking the Installation

After installing the tape drive on your system, check the installation by performing a small write and read operation. This will confirm that the system can communicate with the tape drive and that the tape drive is operational. The simplest method for checking the installation is to use VXATool. VXATool is available for several operating systems and can be downloaded from the support section at: [www.tandberg.com](http://www.tandberg.com)

Check the installation by following these steps:

1. Install VXATool.

Detailed instructions are included in the “readme” file available with the VXATool download.

2. Stop all backup software application services on the system.

If a backup software application is already installed on your system, completely shut down the backup software application and any services it may be running. The backup software application may prevent communications with the tape drive or may interrupt VXATool functions resulting in their failure.

3. Confirm that the system can communicate with the tape drive.

Run VXATool and confirm that it can retrieve basic drive information from the tape drive. Refer to the VXATool readme file or on-line help for instructions.

4. Insert a cartridge and use VXATool to run a write/read test.

Refer to the VXATool readme file or on-line help for instructions on how to run a diagnostic write/read test.

5. Update the firmware.

Updates to the tape drive’s firmware are made available for download from Tandberg Data’s web site at [www.tandberg.com](http://www.tandberg.com). Use VXATool to check the current version of firmware in your tape drive and to update the firmware as needed.

Refer to [Chapter 4](#) for troubleshooting tips if you encounter any problems.

## INTEGRATING THE TAPE DRIVE

After installing the VXA-320 tape drive, you may need to integrate it with your backup software application and computer operating system. The Support section of Tandberg Data's web site, [www.tandberg.com](http://www.tandberg.com), provides a list of backup software applications and operating systems that are compatible with the VXA-320 tape drive.

If your backup software application does not support the VXA-320 tape drive, you can use VXATool to change the product identification information (Inquiry String) that the tape drive returns to the software. Changing the tape drive's identification information does not affect the tape drive's speed or capacity. For instructions on using VXATool to change the tape drive's Inquiry String, refer to the help or readme file provided with VXATool. Additional information is available at: [www.tandberg.com](http://www.tandberg.com) (article #2002).

Refer to the information provided with your backup software application for device integration instructions. Refer any questions regarding software configuration and operation to your software provider.

The CD included with the tape drive provides device drivers for use with the Windows operating system.

---

**!** **Important** Do not install these drivers unless you are using the Windows native backup software application or unless your backup software application instructs you to do so.

---

# 3

## OPERATION

This chapter describes how to operate the tape drive. [Figure 3-1](#) and [Figure 3-2](#) show the controls and indicators on the front panel of the tape drive.

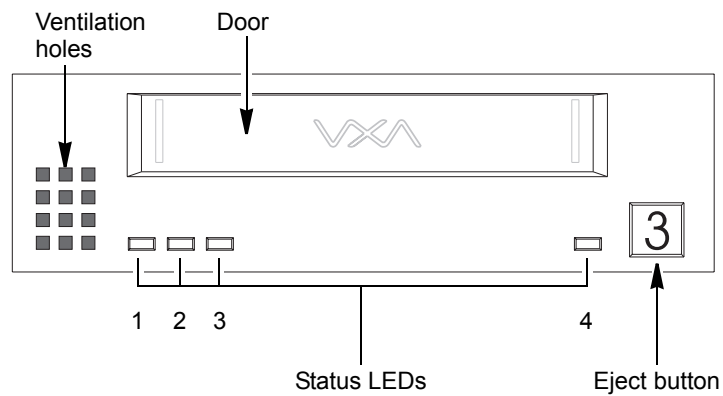

**Figure 3-1** Internal tape drive: front-panel components

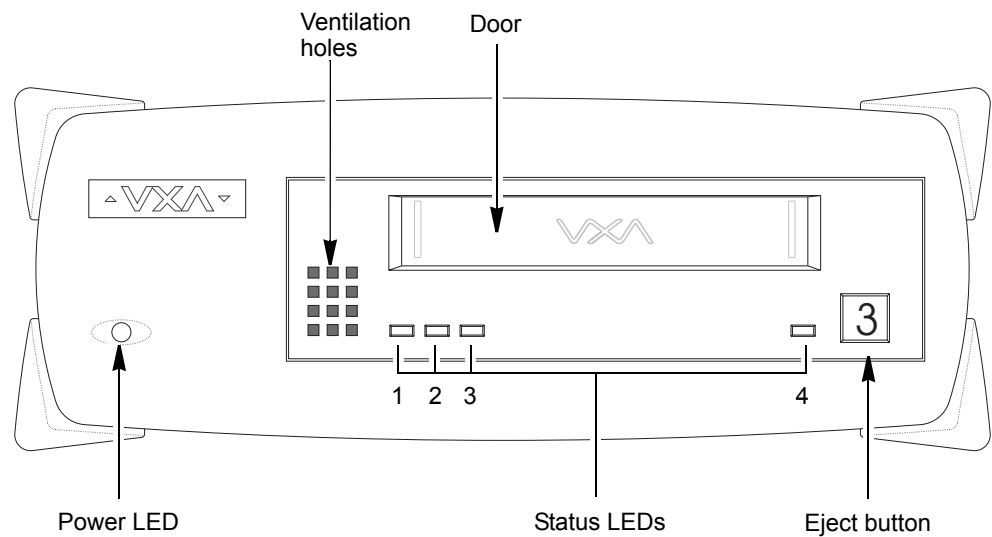



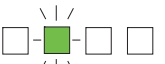



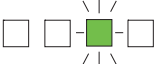

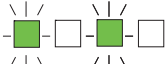

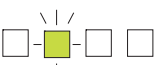
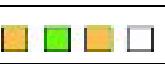

**Figure 3-2** External tape drive: front-panel components

## MONITORING THE LEDs







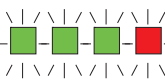

The VXA-320 tape drive uses four LEDs to indicate its operational status, as shown in [Table 3-1](#).

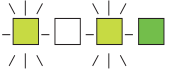
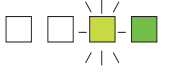
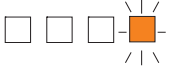
**Note:** The LEDs are numbered 1 through 4 from left to right.

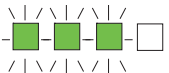
**Table 3-1** LED states

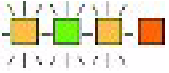
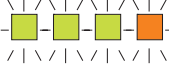
Operation	LED Pattern	LED #1	LED #2	LED #3	LED #4
<b>Operational Conditions</b>					
Power-on self-test	LEDs illuminate sequentially <sup>a</sup>				
No tape loaded		Off	Off	Off	Green
Interface activity; (LED 4 may flash with other LED operations)		Off	Off	Off	Flashing Green
Tape loading or unloading		Off	Flashing Green	Off	Off
Tape ready; idle		Off	Green	Off	Off
Reading		Off	Off	Green	Off or Flashing Green
Writing		Off	Amber or Green <sup>b</sup>	Amber	Off or Flashing Green
Space forward		Off	Off	Flashing Green	Off
Space reverse or rewinding		Flashing Green	Off	Off	Off
Cleaning in process		Flashing Green	Off	Flashing Green	Off
<b>Service Notification</b>					
Cleaning required		Off	Flashing Amber	Off	Off
Cleaning tape used up		Off	Flashing Green/Amber	Off	Off
Recoverable error <sup>c</sup>		Amber	Green	Amber	Off or Green
Unrecoverable error <sup>c</sup>		Amber	Off	Amber	Off or Green
Factory service required <sup>d</sup>		Flashing Green or Amber			Flashing Red

**Table 3-1** LED states (continued)

Operation	LED Pattern	LED #1	LED #2	LED #3	LED #4	
<b>Service Notification (continued)</b>						
Broken tape		Flashing Green/Amber	Off	Flashing Green/Amber	Green	
Format recovery <sup>e</sup>		Off	Off	Flashing Green/Amber	Green	
Temperature too high in tape path <sup>f</sup>		Off	Off	Off	Flashing Orange	
Boot Block Mode <sup>g</sup>		Flashing Green	Flashing Amber	Flashing Orange	Flashing Green	
<b>Self Test</b>						
Self-test running		Fast scrolling green				Off or Flashing Green
Self-test passed		Green	Green	Green	Off	
Self-test failed <sup>h</sup>		Amber	Amber	Amber	Off	
<b>Firmware Load</b>						
Loading firmware		Flashing Amber	Flashing Green	Flashing Amber	Orange	
Loading firmware		Flashing Green/Amber	Flashing Green/Amber	Flashing Green/Amber	Orange	
<b>KEY:</b> Flashing LEDs =  On =  Off = 						

<sup>a</sup> For the power-on self-test, the LEDs scroll sequentially right to left then left to right in amber and green. LED 4 illuminates in red and green. When POST is completed, LED 4 is illuminated in green.

<sup>b</sup> When LED 2 is amber, hardware compression is enabled. When LED 2 is green, hardware compression is disabled.

<sup>c</sup> Retry the operation with another tape, making sure that the tape is not written in VXA-1 format. If the problem persists, try power cycling the tape drive to clear the error. If you cannot resolve the problem yourself, contact Tandberg Data Technical Support (see [“Contacting Tandberg Data”](#) on page iv). To capture a log of a problem, use VXATool, which is available as a free download from [www.tandberg.com](http://www.tandberg.com).

<sup>d</sup> You may need to return the tape drive for service; contact Tandberg Data Technical Support. To get a log of the problem, use VXATool, which is available as a free download from [www.tandberg.com](http://www.tandberg.com).

<sup>e</sup> The tape was written without a valid end-of-data mark, which often occurs if you power-down the tape drive while the tape drive was writing. The tape drive will perform a format recovery, which involves reading the data to determine where the end of data is located. This may take as long as 2 to 3 hours.

<sup>f</sup> Refer to [“LED 4 is Flashing Orange”](#) on page 26 for troubleshooting information.

<sup>g</sup> If the tape drive is in Boot Block Mode, try power cycling the tape drive. If it remains in Boot Block Mode, load new firmware. VXA-320 firmware is available at [www.tandberg.com](http://www.tandberg.com).

<sup>h</sup> If a self-test fails, clean the tape drive with a VXAtape cleaning cartridge. If the failure still occurs, try a new tape.

## USING VXATAPE CARTRIDGES

The tape drive uses data-quality VXAtape data cartridges, in various lengths, available from Tandberg Data and authorized sources. These cartridges do not require formatting or other media conditioning before use. See [Table 7-1 on page 49](#) for compatibility and capacity information for VXAtape cartridges. See [page 23](#) for storage guidelines.



### Caution

The VXA-320 tape drive only operates with VXAtape data cartridges. Do not attempt to use other types of cartridges, or you may damage the tape drive.

### SETTING THE WRITE-PROTECT SWITCH

Before you insert a cartridge into the tape drive, make sure the write-protect switch on the cartridge is set correctly, as shown in [Figure 3-3](#).

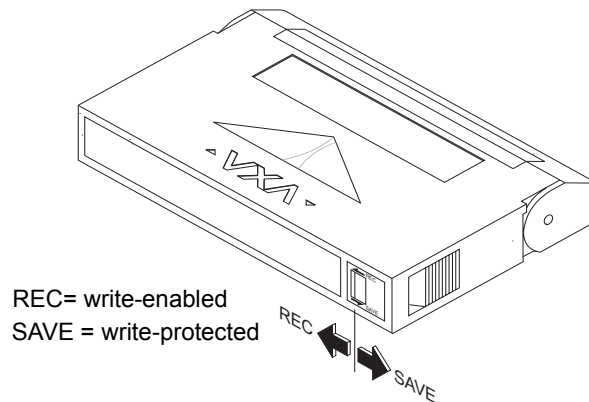

**Figure 3-3** Setting the write-protect switch

### LOADING A CARTRIDGE

Insert the front of the cartridge through the tape drive door into the loader mechanism. (The colored write-protect tab on the cartridge should be closest to the tape drive's eject button.) Gently push the cartridge until the tape drive's loader mechanism activates and completes the tape-loading process.

The tape drive loads the tape in approximately 40 seconds, during which time, LED 2 flashes green. When LED 2 is steady green, the tape drive is ready to begin write and read operations.

### UNLOADING A CARTRIDGE

To unload a cartridge, press the eject button. The tape drive completes any command in process, writes any buffered information to tape, rewinds to the beginning of the tape, and ejects the cartridge in approximately 1 to 2 minutes.

## STORING THE CARTRIDGES

If VXA tape cartridges are stored properly, you can expect to successfully recover data from them for 30 years. Be aware that the 30-year storage life is for an archival tape, not a tape being used for daily backups.

As a general rule, use a new (or relatively unused) cartridge to store any critical data you may need to recover many years from now. Do not use a cartridge that has reached its retirement point. For routine backups that get overwritten each day or week, it is acceptable to reuse cartridges until they are ready for retirement.

Proper storage of cartridges helps prevent media-related problems. To ensure a storage period of 30 years, follow these guidelines:

- ▶ Remove the cartridge from the tape drive and store it as soon as possible after you have finished writing or reading data. Avoid handling the cartridge excessively. Never open the cartridge door or touch the tape.
- ▶ Label each cartridge.
- ▶ Set the cartridge write-protect switch to prevent accidental over-writing by moving the switch to the edge of the cartridge. (See [page 22](#).)
- ▶ Keep each cartridge in its protective case or a container designed for cartridge storage.
- ▶ Store cartridges away from copiers and printers to avoid contamination by toner and paper dust.
- ▶ Store cartridges away from objects or devices that emit strong magnetic fields.

## CLEANING THE TAPE DRIVE

This section describes when and how to clean the tape drive to maintain optimal performance. Circulating air may introduce debris into the tape path. If debris builds up on the heads, error rates increase and backups take longer because the tape drive must rewrite the data. The VXA-320 tape drive includes an internal cleaning wheel to remove contamination from the tape path. However, you should still clean the tape drive regularly with a separate cleaning cartridge to maximize tape drive reliability and the life of your tapes.

### DETERMINING WHEN TO CLEAN THE TAPE DRIVE

When the tape drive requires cleaning, LED 2 flashes amber. The tape drive should be cleaned as soon as possible after this LED begins flashing.

**Note:** Some software applications may notify you that the tape drive requires cleaning. Refer to your software documentation for more information.

## USING A CLEANING CARTRIDGE

Insert a VXAtape Cleaning Cartridge into the tape drive. The tape drive automatically performs the cleaning cycle in less than one minute. When finished, the tape drive ejects the cleaning cartridge and LED 2 turns off.

**Note:** If there are no more cleaning cycles remaining on the cleaning cartridge, the tape drive ejects the cartridge without performing the cleaning and LED 2 flashes green and amber.



### Caution

Do not use any cleaning method other than the VXAtape Cleaning Cartridge (or a cleaning cartridge approved by Tandberg Data for use with VXA tape drives). Using other cleaning methods may void the tape drive's warranty.

Do not rewind and reuse the material in a cleaning cartridge. Reuse may redistribute contaminants previously removed from the tape path. If all cleaning material has been used, discard the cartridge and use a new cleaning cartridge.

---

---

## RESETTING THE TAPE DRIVE

To reset the VXA-320 tape drive, perform one of the following steps:

- ▶ Press and hold the unload button for at least 10 seconds, then release the button. This clears any error, ejects any cartridge that is in the tape drive (unless a hardware error occurred), and resets the tape drive.

**Note:** If the tape drive contains a cartridge, the tape drive rewinds the tape to the beginning before ejecting the cartridge. The time required to complete the rewind depends on what size cartridge you are using and if the tape was positioned near the end.

- ▶ Power down the tape drive. Wait 10 seconds, then turn the tape drive back on. Depending on what function the tape drive was performing before the reset, the tape drive may automatically start a lengthy format recovery process, which involves reading the data to determine where the end of data is located. This may take as long as 2 to 3 hours. Wait for the format recovery to complete.
- ▶ Send a bus device reset (0Ch) message to the tape drive. A device reset clears all input/output (I/O) processes on that SCSI bus.
- ▶ Send a SCSI bus reset. (Make sure no other devices are using the SCSI bus.)

# 4

## TROUBLESHOOTING

This chapter describes problems that you might encounter while operating the VXA-320 tape drive and provides suggestions for resolving the problems.

**Note:** The Support section of the Tandberg Data web site, [www.tandberg.com](http://www.tandberg.com), also provides helpful troubleshooting tips.

### RESOLVING PROBLEMS

#### TAPE DRIVE WILL NOT ACCEPT A CARTRIDGE

If the tape drive does not accept a cartridge when you insert it into the tape drive door, do the following:

1. Determine if there's already a cartridge loaded.

Press the eject button; there may be a cartridge already loaded in the tape drive.

2. Make sure you are using VXATape cartridges with either VXA-2 or VXA-320 (VXA-3) format.
  - ▶ If the cartridge you are attempting to load is not a VXATape cartridge, the tape drive automatically ejects it.
  - ▶ If the cartridge contains data written in VXA-1 format, the tape drive automatically ejects it. The front panel LEDs indicate an unrecoverable error (LEDs 1 and 3 are amber, LEDs 2 and 4 are off).
3. Check that the tape drive is powered on and that it is not indicating an error state on its LEDs. Refer to [Table 3-1 on page 20](#) for a complete list of LED states.
4. Check to see if LED 4 is flashing orange, indicating that the tape drive is over-temperature (see [“LED 4 is Flashing Orange” on page 26](#)).
5. Power cycle the tape drive.

Power down the tape drive. Wait 10 seconds, then turn the tape drive back on.

On power-up, observe the tape drive's LED code sequence. If the LEDs do not illuminate, check the power supply and power cable connection. If the tape drive is installed internally in a server, try connecting a different power cable to the tape drive.

If power to the tape drive was interrupted when you originally attempted to load a cartridge, the tape drive detects the tape when its power is restored and then rewinds the tape. If this is the case, press the eject button, remove the cartridge, and begin the session again.

6. Push the cartridge straight into the tape drive. If the cartridge is inserted or pushed at an angle, you will feel resistance and will not be able to load the cartridge.
7. Check to see if all four LEDs are flashing (LED 1 is green, LED 2 is amber, LED 3 is orange, LED 4 is green), indicating that the tape drive is in Boot Block Mode.

If a firmware upgrade was interrupted or did not complete successfully, the tape drive powers on in Boot Block Mode. Reload the firmware as described in ["Upgrading Firmware" on page 36](#). The tape drive will not accept a cartridge until the firmware is successfully reloaded.

## LED 4 IS FLASHING ORANGE

If LED 4 is flashing orange, the tape drive is over temperature and must cool down before operations can continue. Do the following:

1. Wait for the tape drive to cool.

When the tape drive cools down, LED 4 turns off. Do not attempt to load a cartridge or perform any operations during this time. If there is a tape loaded in the tape drive, press the eject button to unload the tape and move it to a cooler environment.

2. If necessary, power cycle the tape drive.

If the tape drive does not cool down on its own, power down the tape drive. Wait a few minutes, then turn the tape drive back on. If LED 4 is still orange after power-up, the tape drive may be in an environment that is too hot.

- ▶ If the tape drive is an internal model, check that the ventilation fan on the back of the tape drive is not obstructed and that the tape drive is not located near devices that are emitting excessive heat.
- ▶ If the tape drive is an external model, check that the ambient temperature is within the specifications noted in [Table 7-16 on page 58](#). If the temperature is within the specifications, the enclosure's fan may not be working properly and you should return the tape drive for service (see [page 35](#)).

## TAPE DRIVE WILL NOT EJECT A CARTRIDGE

If the tape drive does not eject a cartridge when you press the eject button, do the following:

1. Use your backup application to eject the cartridge.

To protect against accidental tape ejection during a backup or restore operation, many applications prevent using the tape drive's eject button for media removal.

2. If you cannot eject the cartridge through the application, use VXATool to unload the cartridge. Refer to the readme file or on-line help available with VXATool for instructions.
3. Reset the tape drive. Press and hold the unload button for at least 10 seconds, then release the button. This clears any error, ejects any cartridge that is in the tape drive (unless a hardware error occurred), and resets the tape drive.

**Note:** If the tape drive contains a cartridge, the tape drive rewinds the tape to the beginning before ejecting the cartridge. The time required to complete the rewind depends on what size cartridge you are using and if the tape was positioned near the end.

4. Power cycle the tape drive.

Power down the tape drive. Wait 10 seconds, then turn the tape drive back on. Depending on what function the tape drive was performing before the reset, the tape drive may automatically start a lengthy format recovery process, which involves reading the data to determine where the end of data is located. This may take as long as 2 to 3 hours. Wait for the format recovery to complete.

5. If the cartridge appears to be stuck in the tape drive, return the tape drive for service.

If you still cannot eject the cartridge, you may need to return the tape drive for repair with the cartridge in place.

## TAPE DRIVE IS NOT DETECTED BY THE OPERATING SYSTEM OR BACKUP APPLICATION

If the tape drive powers up, loads and unloads cartridges, but is not recognized by the operating system or backup application, do the following:

1. Check the SCSI host bus adapter installation.
  - ▶ Confirm that the tape drive is connected to an LVD SCSI controller. Do not connect the tape drive to a RADI or RAID-enabled controller or to an HVD controller.

- ▶ Check that the SCSI controller and the most recent drivers available for it are installed according to the manufacturer's instructions.
  - ▶ Check that the SCSI controller is fully seated in its slot. You can also try
2. Make sure the tape drive is installed properly on the bus, described in [Chapter 2](#). In particular, check the following:
    - ▶ Is the tape drive set to a unique SCSI ID?
    - ▶ Is a terminator installed at the physical end of the SCSI bus? Try another terminator.
    - ▶ Is there a broken cable or defective connector? Try another, known-good cable.
    - ▶ Is the cable correctly oriented and firmly seated on the tape drive connector?
  3. Check that the tape drive is powered-on and that its LEDs are not indicating an error state. See [Table 3-1 on page 20](#) for a complete list of LED states.
  4. Reboot your system.
  5. Try using VXATool to communicate with the tape drive. Before running VXATool, stop all services for your backup application. If VXATool can detect and communicate with the tape drive, but your backup application cannot, contact the application provider for software support.
  6. Verify that the tape drive is supported by your operating system and backup application. Refer to ["Integrating the Tape Drive" on page 18](#) for details on how to confirm this information.

## A SERVICE NOTIFICATION LED CODE APPEARS

If one of the Service Notification LED codes appears (see [Table 3-1 on page 20](#)), refer to [Table 4-1](#) for error recovery procedures.

**Table 4-1** Service Notification error recovery procedures

Service Notification	Suggested Recovery Procedure
Cleaning Required	Clean the tape drive. See <a href="#">page 23</a> for cleaning instructions; LED 2 flashes amber when the tape drive needs to be cleaned. Use only an Tandberg Data approved VXAtape Cleaning Cartridge.
Cleaning Tape used up	Discard the cartridge and use a new cleaning cartridge. Do not rewind and reuse the material in a cleaning cartridge. Reuse may redistribute contaminants previously removed from the tape path.

**Table 4-1** Service Notification error recovery procedures (continued)

Service Notification	Suggested Recovery Procedure
Recoverable Error\ Unrecoverable Error	Retry the operation with another tape, making sure that the inserted tape was not written in VXA-1 format. If the problem persists, try power cycling the tape drive to clear the error. If you cannot resolve the problem yourself, contact Tandberg Data Technical Support (see <a href="#">“Contacting Tandberg Data” on page iv</a> ). To capture a log of a problem, use VXATool, which is available as a free download from <a href="http://www.tandberg.com">www.tandberg.com</a> .
Factory service required	Power cycle the tape drive. If the problem persists, you may need to return the tape drive for service; contact Tandberg Data Technical Support (see <a href="#">“Contacting Tandberg Data” on page iv</a> ). To get a log of the problem, use VXATool, which is available as a free download from <a href="http://www.tandberg.com">www.tandberg.com</a> .
Broken tape	Make sure there is not a source of bright light shining into the tape drive. Check if the medium in the ejected cartridge is broken. If it is, discard the cartridge and use a new cartridge.
Format recovery	The tape was written without a valid end-of-data mark, which often occurs if you power-down the tape drive while the tape drive was writing. The tape drive will perform a format recovery, which involves reading the data to determine where the end of data is located. This may take as long as 2 to 3 hours. Allow the format recovery operation to complete, and then press the eject button to unload the cartridge. Avoid power-cycling the tape drive while a tape is loaded.
Temperature too high in tape path	Refer to <a href="#">“LED 4 is Flashing Orange” on page 26</a> for troubleshooting information.
Boot block mode	Reload the firmware as described in <a href="#">“Upgrading Firmware” on page 36</a> .

## BACKUP APPLICATION IS REPORTING AN ERROR

Your backup application may report an error as a result of a failure to communicate with the tape drive, a failure by the tape drive to write or read data, or because of a software configuration issue.

### Failure to communicate with the tape drive

Communication problems on the SCSI bus may be reported by the backup application as resets, a loss of communication with the tape drive, failure to detect the tape drive, I/O device errors, or parity errors. These types of errors may occur intermittently. Most often, these issues are due to SCSI cabling and termination problems.

- ▶ Check tape drive installation on the SCSI bus, described in [“Installing the Internal SCSI Tape Drive” on page 8](#) or [“Installing the External SCSI Tape Drive” on page 14](#).
- ▶ Use VXATool to capture the diagnostic log from the tape drive immediately after an error is reported by your backup application. Technical Support can examine the log to determine the nature of the reported error. Refer to [“Capturing a Diagnostic Log” on page 31](#) for instructions.

## Failure by the tape drive to write or read data

If your backup application reports a media error, one of the following situations may have occurred:

- ▶ The tape drive needs cleaning (see [“Cleaning the Tape Drive” on page 23](#)). Always try cleaning the tape drive before you assume the cartridge is bad. Be sure to use a VXAtape Cleaning Cartridge.
- ▶ The cartridge needs to be replaced. Try using a different cartridge for the backup, making sure that the tape is not written in VXA-1 format. Mark any cartridge that fails. If you notice that the same cartridge results in multiple failures, it may be time to replace the cartridge.
- ▶ The backup application has attempted to append data to a cartridge that previously failed. If a write media error previously occurred on the tape, the tape drive cannot append data at the point where the write media error occurred. You can attempt to overwrite the tape, but any attempt to append data will fail.
- ▶ If you are trying to write data, the cartridge may be write-protected. Check the switch on the edge of the cartridge (see [Figure 3-3 on page 22](#)). If the switch does not cover the opening, the tape is write-protected. If the switch covers the opening, you can write to the tape. Use a pen or small screwdriver to move the switch.
- ▶ If you used an application other than your normal backup application to write data to the tape, your backup application may report that it does not recognize the tape. For example, if you have used VXATool to write and read test data, the test tape will not be “recognized” by your backup application. Perform a tape erase using either VXATool or your backup application.

## Backup Application configuration issues

If you suspect an issue with the backup application configuration, use VXATool to first confirm that the hardware is working properly. Run a VXATool Write/Read test to verify that the tape drive is communicating over the SCSI bus and that it can perform write and read operations. The readme file that accompanies the program (or the online help for the Windows version) provides instructions for using VXATool.

For any questions regarding software configuration, contact your software provider.

## TROUBLESHOOTING WITH VXATOOL

To troubleshoot problems with the tape drive, you can use the VXATool diagnostic software. This program allows you to conduct diagnostic testing and update the firmware. VXATool is available for a variety of operating environments.

Download VXATool free of charge from the Support section of Tandberg Data's web site at [www.tandberg.com](http://www.tandberg.com). The readme file that accompanies the program (or the online help for the Windows version) provides instructions for using VXATool.

---

**!** **Important** Always check Tandberg Data's web site to make sure that you have the most current version of VXATool.

---

### GETTING STARTED (IMPORTANT FIRST STEP)

Before running VXATool—completely shut down your backup application and any services it may be running. The backup application may prevent communications with the tape drive or may interrupt VXATool functions resulting in their failure.

### PERFORMING A WRITE/READ TEST

Use VXATool to perform a Write/Read test of the tape drive. The Write/Read test verifies that the tape drive is communicating over the SCSI bus and that it can perform write and read operations. Refer to the readme file or on-line help available with the VXATool for detailed instructions.

### UPDATING FIRMWARE

As improvements to tape drive firmware are made, they are made available for download from Tandberg Data's web site at [www.tandberg.com](http://www.tandberg.com). Use VXATool to check the current version of firmware in your tape drive and to update the firmware as needed.

### CAPTURING A DIAGNOSTIC LOG

A diagnostic log is a snapshot of the tape drive's current condition. If the tape drive reports an error, use VXATool to capture the diagnostic log as soon as possible after the error occurred. To ensure that the diagnostic log accurately reflects the condition of the tape drive when the error occurred, avoid disturbing the tape drive (for example, power-cycling, loading or unloading tapes, or writing or reading more data) before capturing the diagnostic log.

## GATHERING TROUBLESHOOTING INFORMATION FOR TECHNICAL SUPPORT

Before contacting Tandberg Data Technical Support, complete the following steps to gather all of the required information. Having this information available before you call Technical Support will allow your representative to help you as efficiently as possible. When you have all of the required information see “[Contacting Tandberg Data](#)” on [page iv](#) to contact Technical Support.

### VXA-320 TAPE DRIVE INFORMATION

- ▶ **Serial number.** What is the tape drive’s serial number? The serial number is located on the label attached to the tape drive (see [Figure 1-6 on page 5](#)). Alternatively, you can use VXATool to display the tape drive serial number.
- ▶ **Firmware level.** What version of firmware is currently loaded in the tape drive? Use VXATool to display the current version of firmware in your tape drive. Check [www.tandberg.com](http://www.tandberg.com) for the latest release of VXA-320 tape drive firmware. If your tape drive is not at the latest firmware level, use VXATool to update the firmware.
- ▶ **Tape drive configuration.** Is the tape drive an internal model (installed in a server); external model; or integrated within a library?
- ▶ **LED status.** Do the tape drive LEDs indicate an error state? Refer to [Table 3-1 on page 20](#) for a description of the LED states.

### SCSI BUS INFORMATION

- ▶ **SCSI host bus adapter make and model.** What is the make and model of SCSI host bus adapter connected to the tape drive? Make certain that the LVD SCSI host bus adapter and any necessary drivers installed in the host computer are compatible with the High-density, LVD tape drive. Tandberg Data does not support using the tape drive on a RAID controller.
- ▶ **SCSI bus configuration.** What is the configuration of the SCSI bus used by the tape drive?
  - ▶ Are other SCSI devices attached to the SCSI bus?
  - ▶ What are the SCSI IDs of all devices attached to the same bus (both internal and external devices)?
  - ▶ Is the SCSI bus terminated at the physical end of the bus?
  - ▶ What is the total SCSI cable length for all devices (both internal and external devices) on the SCSI bus? See [page 9](#) for information about determining the total SCSI bus length for the internal tape drive and [page 15](#) for information about determining the total SCSI bus length for the external tape drive.

- ▶ Check all SCSI cables connectors for bent pins and confirm that all connectors are firmly seated.

## OPERATING SYSTEM INFORMATION

- ▶ **Operating system.** What operating system is being used? Are all current patches installed?
- ▶ **Device drivers.** Are the appropriate drivers installed for the SCSI host bus adapter? Refer to the installation instructions for your SCSI host bus adapter card.

## BACKUP APPLICATION INFORMATION

- ▶ **Backup application name and version.** What backup application is being used?
- ▶ **Compatibility.** Does your application support the VXA-320 (VXA-3) tape drive? Refer to the supported hardware devices list from the application provider.
- ▶ **Device driver.** Is the appropriate driver installed for the tape drive? Refer to the installation instructions for your backup application.
- ▶ **Backup application log files.** Have the log files from your backup application ready to send to Technical Support.

## TAPE DRIVE DIAGNOSTIC INFORMATION

- ▶ **Write/Read test results.** Use VXATool and run a Write/Read test and then capture the diagnostic log from the tape drive and save it to a file. Have the diagnostic log file ready to send to Technical Support. Refer to the readme file or on-line help available with the VXATool for detailed instructions.

If the VXATool Write/Read test reports an error, clean the tape drive and run the test again on a new tape.

- ▶ **Diagnostic log taken after an error.** Use VXATool to capture the diagnostic log from the tape drive immediately after your backup application reports an error.

## NOTES

# 5

## SERVICE AND MAINTENANCE

This chapter provides information about service and maintenance for the tape drive, including:

- ▶ Returning the tape drive for service
- ▶ Upgrading firmware
- ▶ Obtaining a diagnostic listing

### RETURNING THE TAPE DRIVE FOR SERVICE

If you need to return the tape drive to the factory for service, follow these steps:

1. Before returning a tape drive for service, contact Tandberg Data Service (see [page iv](#)) or your Tandberg Data authorized service provider for return authorization and shipping instructions. If your service provider instructs you to return the tape drive directly to Tandberg Data, contact Tandberg Data Service to obtain a Return Materials Authorization (RMA) number and the shipping address.
2. Remove and keep all cartridges, cables, and terminators.

**Caution**

If a cartridge is stuck in the tape drive, do not attempt to manually extract it. You could damage the cartridge or tape drive. An FAQ (#282) at Tandberg Data's web site [atv](#) provides more information.

If necessary, contact Tandberg Data Technical Support for assistance.

---

---

3. When repacking and shipping a tape drive, use the original shipping carton and packing materials (or replacement packaging obtained from Tandberg Data) to avoid damaging the tape drive. The shipping and packaging materials are not intended for shipping items other than VXA-320 tape drives.

**Caution**

Tandberg Data is not responsible for shipping damage caused by an improperly packaged tape drive.

To avoid damaging the tape drive and voiding your warranty, use the original shipping materials (or replacement materials from your vendor).

---

---

## UPGRADING FIRMWARE

You can obtain firmware for the VXA-320 tape drive from the Tandberg Data web site or from Tandberg Data Technical Support. To upgrade the software, you need to use VXATool, a diagnostic program used on the host computer for configuring, troubleshooting, and upgrading firmware in the VXA-320 tape drive over the tape drive's SCSI interface. VXATool is available for a variety of operating environments.

Download VXATool free of charge from the Support section of Tandberg Data's web site at [www.tandberg.com](http://www.tandberg.com). The readme file that accompanies the program (or the online help for the Windows version) provides instructions for using VXATool.

---

**! Important** Always check Tandberg Data's web site to make sure that you have the most current version of VXATool.

---

## OBTAINING A DIAGNOSTIC LISTING

You can obtain a diagnostic listing (dump) from the tape drive using VXATool (described in the previous section). You can download the VXATool program from Tandberg Data's web site at [www.tandberg.com](http://www.tandberg.com). The readme file that accompanies the program (or the online help for the Windows version) provides instructions for creating a diagnostic listing.

# 6

## COMMUNICATION INTERFACE AND COMMAND PROTOCOL

This chapter provides an overview of the communication interface and command protocol used by the VXA-320 (VXA-3) tape drive. It includes the following topics:

- ▶ Communication interface versus command protocol
- ▶ SCSI communication interface
- ▶ SCSI interface requirements
- ▶ SCSI command protocol

### COMMUNICATION INTERFACE VERSUS COMMAND PROTOCOL

When a device is connected to a host computer, their interaction is accomplished via a *communication interface* (for example, a parallel SCSI bus). The communication interface is comprised of the physical interface (for example, cables, connectors, and control circuitry) and the signaling protocol used during communication.

The physical interface determines the number of devices that can be attached to a bus or network loop, the maximum length of the cables, and the physical characteristics of the cable itself (for example, the number of wires, shielding, and so forth). The signaling protocol defines the electrical characteristics and timing of signals carried by the cable, the message system requirements, transmission speeds and maximum data transfer rates, as well as the encoding and decoding of the individual bit patterns representing commands passing between the individual devices.

The format and content of the information carried over the communication interface, as well as how each device uses and responds to the information, is governed by a *command protocol*. The command protocol determines how the host (or initiator) interacts with the target device (for example, the tape drive) by issuing commands to control its operation, transferring data, and responding to status information. The target device responds to commands from the host by performing the requested operation (for example, writing or reading data on magnetic tape) and returning status information.

The VXA-320 tape drive is available with a parallel SCSI communication interface. This communication interface provides a method of passing SCSI command descriptor blocks (CDBs) over an bus. The operation of the tape drive is governed by the SCSI command protocol.

The following section describes how the SCSI communication interface is implemented in the tape drive. [“SCSI Interface Requirements” on page 40](#) describes the physical requirements of the SCSI bus. [“SCSI Command Protocol” on page 44](#) provides information about the SCSI command protocol used by the tape drive. Refer to the *VXA-320 (VXA-3) Tape Drive SCSI Reference* for detailed information about the SCSI communication interface and command protocol.

## SCSI COMMUNICATION INTERFACE

This section provides an overview of the SCSI communication interface used by the VXA-320 tape drive.

### SCSI BUS PHASES

Bus phases determine the direction and type of information transferred across the data lines of the SCSI bus. The possible bus phases include Bus Free, Arbitration, Selection, Reselection, and Transfer (which includes four subsets: Message In or Message Out, Command Out, Data In or Data Out, and Status In). [Table 6-1](#) describes the bus phases.

**Table 6-1** SCSI bus phases and information transfer phases

Bus Phase	Description
<b>Bus Free</b>	The Bus Free phase specifies that no device is using the bus.
<b>Arbitration</b>	The Arbitration phase allows devices to compete for access on the bus.
<b>Selection</b>	The Selection phase allows an initiator to select the tape drive for communication.
<b>Reselection</b>	The Reselection phase allows the tape drive to reconnect to the initiator after it disconnects.

**Table 6-1** SCSI bus phases and information transfer phases

Bus Phase	Description
<b>Transfer:</b> <ul style="list-style-type: none"> <li>▪ Message In/Message Out</li> <li>▪ Command Out</li> <li>▪ Data In/Data Out</li> <li>▪ Status In</li> </ul>	<p>The Message phases help manage the physical path between the initiators and targets.</p> <ul style="list-style-type: none"> <li>▪ In the Message In phase, the tape drive sends a message to the initiator. In the Message Out phase, the initiator sends a message to the tape drive.</li> <li>▪ In the Command Out phase, the initiator sends a command to the tape drive. Commands contain information about what actions the tape drive should perform.</li> <li>▪ In the Data In phase, the tape drive transfers data to the initiator. In the Data Out phase, the initiator transfers data to the tape drive.</li> <li>▪ In the Status In phase, the tape drive returns a status byte to the initiator. The status byte indicates the results of the command's execution.</li> </ul>

## SCSI MESSAGE SYSTEM

The SCSI message system allows communication between a SCSI initiator and the VXA-320 tape drive for interface management. This message system or command set is separate from the SCSI command protocol used to control the operation of the tape drive. A message can be one byte or multiple bytes.

[Table 6-2](#) describes the SCSI messages that the tape drive supports.

**Table 6-2** SCSI messages supported by the tape drive

Message	Hex Code	Description
Task Complete	00h	The tape drive informs the initiator that the execution of the command was completed and that it sent a valid status byte to the initiator.
Extended Messages	01h	<b>Synchronous Data Transfer Request (01h)</b> The tape drive supports synchronous data transfer.
		<b>Wide Data Transfer Request (03h)</b> The tape drive supports wide data transfer.
		<b>Parallel Protocol Request (04h)</b> The tape drive supports negotiating a synchronous data transfer agreement, a wide data transfer agreement, and setting the protocol options between two SCSI devices.
Save Data Pointer	02h	The tape drive requests that the initiator copy the current data pointer for possible use by the Restore Pointers message during error recovery.
Restore Pointers	03h	The tape drive informs the initiator that it did not properly receive a block of data or the command descriptor block (CDB) and that the data needs to be transferred again.
Disconnect	04h	The tape drive informs the initiator that it plans to disconnect from the SCSI bus and that a reconnect will be required later.
Initiator Detected Error	05h	The initiator informs the tape drive that an error occurred. The tape drive can retry the operation.

**Table 6-2** SCSI messages supported by the tape drive (continued)

Message	Hex Code	Description
Abort Task Set	06h	The initiator is clearing the present and any pending operation for that initiator. When the tape drive accepts this message, it releases the bus into the Bus Free phase.
Message Reject	07h	Either the initiator or the tape drive is indicating that the last message received was inappropriate or not implemented.
No Operation	08h	The initiator informs the tape drive that it does not have a valid message to send in response to the tape drive's request for a message.
Message Parity Error	09h	The initiator informs the tape drive that one or more bytes in the last message it received had a parity error.
Target Reset	0Ch	The initiator instructs the tape drive to reset all of its current I/O operations. The tape drive releases the SCSI bus into the Bus Free phase, with no operations pending for any initiator, and performs a reset. (See <a href="#">page 24</a> for more information about resetting the tape drive.)
Ignore Wide Residue	23h	The tape drive sends the Ignore Wide Residue message to indicate that the number of valid bytes sent was less than the negotiated transfer width.
Identify	80h or C0h	This message is used to establish a physical path connection between the initiator and the tape drive. It also indicates whether disconnect is supported and the LUN for which the command is intended. The tape drive supports a LUN of 0.

## SCSI INTERFACE REQUIREMENTS

The VXA-320 tape drive is available with a wide, High-density (HD) 68-pin, low-voltage differential (LVD) SCSI interface. This section provides general information about the specifications for the tape drive's Small Computer System Interface (SCSI), including:

- ▶ SCSI cable requirements
- ▶ SCSI connector requirements
- ▶ Terminator requirements

---

**!** **Important** Although the tape drive's High-density, 68-pin LVD SCSI interface is compatible with both single-ended and narrow SCSI buses, to avoid performance issues Tandberg Data does not recommend using the tape drive on either of these buses.

---

## INTERNAL TAPE DRIVE

This section describes the cable, connector, and terminator requirements for the internal High-density, 68-pin LVD SCSI tape drive.

### SCSI Cable Requirements

The cable connected to the tape drive SCSI connector must meet the SCSI-3 specifications listed in [Table 6-3](#).



#### Caution

Using a noncompliant SCSI cable will degrade VXA-320 performance and can cause random, nonreproducible errors. Tandberg Data recommends using shielded cables.

**Table 6-3** SCSI cable and connector specifications

Specification	Requirement
General	Wide, LVD SCSI-3
Connector	High-density, 68-pin, male
Maximum length <sup>a</sup>	12 meters (39.2 feet)
Stub length	<ul style="list-style-type: none"> <li>▪ No greater than 0.1 meters should be used off the mainline connection within any connected equipment.</li> <li>▪ The stub length within the tape drive is less than 2.5 centimeters (1 inch).</li> </ul>
Impedance	Between 90 and 140 ohms. An impedance of greater than 100 ohms is recommended. To minimize discontinuities and signal reflections, all cables on the bus should have the same impedance.
Conductor size	28 AWG (0.08097 mm <sup>2</sup> ) A minimum of 28 AWG will minimize noise effects and ensure proper distribution of terminator power.

<sup>a</sup> The maximum length of 12 meters only applies to an LVD SCSI bus. If a single-ended device is connected anywhere on the bus, all devices on the bus operate in single-ended mode. When operating in single-ended mode, the maximum allowable bus length is 3 meters (9.8 feet), terminator to terminator. Exceeding the maximum cable length will result in unstable and unpredictable operation.

## SCSI Connector Requirements

Table 6-4 lists the pin assignments for the tape drive's SCSI connector.

**Table 6-4** Pin assignments for the wide LVD connector

Pin #	Signal	Pin #	Signal
1	+DB (12)	35	-DB (12)
2	+DB(13)	36	-DB(13)
3	+DB(14)	37	-DB(14)
4	+DB(15)	38	-DB(15)
5	+DB(P1)	39	-DB(P1)
6	+DB(0)	40	-DB(0)
7	+DB(1)	41	-DB(1)
8	+DB(2)	42	-DB(2)
9	+DB(3)	43	-DB(3)
10	+DB(4)	44	-DB(4)
11	+DB(5)	45	-DB(5)
12	+DB(6)	46	-DB(6)
13	+DB(7)	47	-DB(7)
14	+DB(P)	48	-DB(P)
15	GROUND	49	GROUND
16	DIFFSENS	50	GROUND
17	TERMPWR	51	TERMPWR
18	TERMPWR	52	TERMPWR
19	OPEN	53	OPEN
20	GROUND	54	GROUND
21	+ATN	55	-ATN
22	GROUND	56	GROUND
23	+BSY	57	-BSY
24	+ACK	58	-ACK
25	+RST	59	-RST
26	+MSG	60	-MSG
27	+SEL	61	-SEL
28	+C/D	62	-C/D
29	+REQ	63	-REQ
30	+I/O	64	-I/O
31	+DB(8)	65	-DB(8)
32	+DB(9)	66	-DB(9)
33	+DB(10)	67	-DB(10)
34	+DB(11)	68	-DB(11)

## SCSI Terminator Requirements

If the internal tape drive is the last device on the SCSI bus, you must terminate the bus by installing a pass-through LVD/SE terminator on the tape drive's SCSI connector. Or, if there is an unused connector at the end of the SCSI cable, you can terminate the bus there. If the cable provided with your adapter has a built-in terminator, do not add another terminator to the bus.

**Note:** If you will be installing the tape drive in an enclosure and using an external terminator, you must install a high-quality active LVD terminator that complies with the SCSI-3 specification.

## EXTERNAL TAPE DRIVE

This section describes the cable, connector, and terminator requirements for the external LVD SCSI tape drive.

### SCSI Cable Requirements

For the external tape drive, select a cable that complies with the SCSI-3 specification and meets the requirements listed in [Table 6-5](#).

**Table 6-5** SCSI cable requirements

Specification	Requirement
Connector type	68-pin male, high-density, shielded, SCSI-3 compliant
Maximum length <sup>a</sup>	12 meters (39 feet) <sup>b</sup>

<sup>a</sup> The maximum length of 12 meters only applies to an LVD SCSI bus. If a single-ended device is connected anywhere on the bus, all devices on the bus operate in single-ended mode. When operating in single-ended mode, the maximum allowable bus length is 3 meters (9.8 feet), terminator to terminator. Exceeding the maximum cable length will result in unstable and unpredictable operation.

<sup>b</sup> If only two devices are attached to an LVD bus in a point-to-point configuration, the maximum allowable cable length is 25 meters (82 feet).

## SCSI Terminator Requirements

If the external tape drive is the last device on the SCSI bus, you must terminate the bus by installing a high-quality active LVD/SE terminator that complies with the SCSI-3 specification on one of the tape drive's SCSI connectors.

## SCSI COMMAND PROTOCOL

This section provides an overview of the SCSI command protocol supported by the VXA-320 (VXA-3) tape drive.

### COMMAND SET

Table 6-6 lists and briefly describes the command set supported by the tape drive.

**Table 6-6** SCSI command set

Command	Operation Code	Description
ERASE	19h	Causes the tape drive to erase all data from the current location to the end of partition.
INQUIRY	12h	Requests that information about tape drive parameters be sent to the initiator.
LOAD/UNLOAD	1Bh	Causes the tape drive to load or unload a cartridge.
LOCATE	2Bh	Positions the tape at a specified logical position or changes partitions. (Typically, this position is determined by data that was obtained through a previous READ POSITION command.)
LOG SELECT	4Ch	Manages a set of internal counters regarding read and write error recovery operations and amounts of data compressed. The initiator can set threshold and cumulative values for the counters or reset the counters.
LOG SENSE	4Dh	Returns the values of the counters managed by the LOG SELECT command.
MODE SELECT	15h	Allows you to specify medium, logical unit, and device parameters.
MODE SENSE	1Ah	Enables the tape drive to report medium, logical unit, or device parameters.
PREVENT/ALLOW MEDIUM REMOVAL	1Eh	Allows or disallows the removal of the cartridge from the tape drive.
READ	08h	Transfers one or more bytes or blocks of data from the tape to the initiator.
READ BLOCK LIMITS	05h	Requests that the tape drive return data identifying the maximum and minimum logical block lengths supported.
READ BUFFER	3Ch	Creates a diagnostic listing of the tape drive's current state or the contents of the tape drive's data buffer.
READ POSITION	34h	Reports the tape drive's current logical position, but does not cause tape motion to occur. Used in conjunction with the LOCATE command.

**Table 6-6** SCSI command set (continued)

Command	Operation Code	Description
RECEIVE DIAGNOSTIC RESULTS	1Ch	Reports the results of the tests requested by a previous SEND DIAGNOSTIC command.
RELEASE UNIT	17h	Releases the tape drive from exclusive use by the initiator that had previously reserved it with a RESERVE UNIT command.
REQUEST SENSE	03h	Requests that the tape drive transfer sense data to the initiator.
RESERVE UNIT	16h	Reserves the tape drive for exclusive use by the initiator that issued the command.
REWIND	01h	Causes the tape drive to rewind the tape to the logical beginning of partition.
SEND DIAGNOSTICS	1Dh	Causes the tape drive to perform certain self-diagnostic tests.
SPACE	11h	Enables the tape drive to perform forward or backward searches using logical blocks, filemarks, or setmarks. Also allows spacing to end of data (EOD).
TEST UNIT READY	00h	Allows you to determine if the tape drive is ready to accept an appropriate medium access command.
VERIFY	13h	Enables the tape drive to verify one or more logical blocks of data on the tape.
WRITE	0Ah	Transfers one or more bytes or blocks of data from the initiator to the tape drive.
WRITE BUFFER	3Bh	Transfers new microcode from the initiator into the tape drive's EEPROM.
WRITE FILEMARKS	10h	Causes the tape drive to write any data remaining in its buffer, then to write one or more filemarks or setmarks to tape.

## STATUS BYTES

After the tape drive executes a command, it issues a status byte to the initiator that indicates whether it performed the command successfully. [Table 6-7](#) describes the four status bytes supported by the tape drive.

**Table 6-7** Status byte descriptions

Status byte	Hex value	Description
Good	00h	Indicates that the tape drive successfully completed the operation.
Check Condition	02h	Indicates that an error, exception, or abnormal condition has caused sense information to be set. The initiator can issue a REQUEST SENSE command to access this information.
Busy	08h	Indicates that the tape drive is busy. This status is sent whenever the tape drive is unable to accept a command from an initiator.
Reservation Conflict	18h	Indicates that the tape drive is reserved for the exclusive use of another initiator.

## SENSE KEYS

When the tape drive returns Check Condition status to the initiator, the initiator can issue a REQUEST SENSE (03h) command to receive information about the error, exception, or abnormal condition. This information includes a sense key, which describes the general error or change of state. [Table 6-8](#) describes the sense keys supported by the tape drive. Refer to the VXA-320 (VXA-3) *Tape Drive SCSI Reference* for a detailed explanation of the information returned by the REQUEST SENSE (03h) command.

**Table 6-8** Supported sense keys

Sense key	Hex Value	Description
No Sense	0h	Indicates that there is no specific sense key information to be reported.
Recovered Error	1h	Indicates that the last command completed successfully with some recovery action performed by the tape drive. Details may be available by examining the additional sense bytes and the information field.
Not Ready	2h	Indicates that the tape drive does not contain a data cartridge or that the data cartridge is not loaded. Operator intervention may be required to correct this condition.
Medium Error	3h	Indicates that the command terminated with a non-recoverable error condition that may have been caused by a flaw in the tape or an error in the recorded data. The tape drive may also return this sense key if it is unable to distinguish between a flaw in the tape and a specific hardware failure (sense key 4h).
Hardware Error	4h	Indicates that the tape drive detected a non-recoverable hardware failure (for example a device failure or parity error) while performing the command or during a self-test.

**Table 6-8** Supported sense keys (continued)

Sense key	Hex Value	Description
Illegal Request	5h	Indicates that there was an illegal parameter in the CDB or in the additional parameters supplied as data for a command or that the tape drive is in the wrong mode to execute the command. If the tape drive detects an invalid parameter in the CDB, the tape is not written. If the tape drive detects an invalid parameter in the additional parameters supplied as data, the tape may already be altered. This sense key can also indicate an invalid Identify message.
Unit Attention	6h	Indicates one of the following: <ul style="list-style-type: none"> <li>▪ The tape drive has been reset (by a power-on reset, a Bus Device Reset message, or a SCSI bus reset).</li> <li>▪ An initiator changed the MODE SELECT parameters since the last command was issued to the tape drive.</li> <li>▪ The eject button was pressed and the data cartridge was ejected.</li> <li>▪ A data cartridge was inserted and automatically loaded.</li> <li>▪ The internal microcode (firmware) was changed.</li> <li>▪ A log parameter (counter) reached a specified threshold value (assuming that RLEC bit on the MODE SELECT Control Mode page is set to 1).</li> </ul> This sense key is reported the first time any command is issued by each initiator after the condition is detected, and the requested command is not performed. This sense key is cleared when the next command other than INQUIRY or REQUEST SENSE is received by the tape drive.
Data Protect	7h	Indicates that a command that writes to tape was attempted on a write-protected data cartridge. The write operation is not performed.
Blank Check	8h	Indicates that the tape drive encountered blank tape or format-defined EOD (blank tape) during a read, space, or locate operation.
Aborted Command	Bh	Indicates that the tape drive aborted the command. This condition occurs when an Initiator Detected Error (05h) message is received during command execution or when a Message Reject (07h) or SCSI bus parity error is detected by the tape drive during Command or Data Out phase. The initiator may be able to recover by trying the command again.
Volume Overflow	Dh	Indicates that the last WRITE or WRITE FILEMARKS command reached the physical end of tape (PEOT) and that data may remain in the buffer.
Miscompare	Eh	Indicates that the source data did not match the data read from the tape.

## NOTES

## 7

## SPECIFICATIONS

This chapter provides specifications for the VXA-320 tape drive. This chapter provides the following specifications for the internal and tabletop models of the tape drive:

- ▶ Data capacities
- ▶ Performance specifications
- ▶ Reliability specifications
- ▶ Size and weight
- ▶ Power specifications
- ▶ Environmental specifications
- ▶ Shipping specifications
- ▶ Safety and regulatory agency compliance

### DATA CAPACITIES

[Table 7-1](#) lists the data capacities for the VXA tape cartridge models supported by the VXA-320 tape drive.

**Table 7-1** Data capacities in gigabytes (GB)

Cartridge Model <sup>a</sup>	Tape Length	Capacity, <sup>b</sup> Native (GB) <sup>c</sup>	Capacity, <sup>a</sup> Compressed (GB) <sup>d</sup>
X23 or V23	230 meters	160	320
X10	124 meters	86	172
X6	62 meters	40	80

<sup>a</sup> The VXA-320 (VXA-3) tape drive does not support VXA tape V6, V10, or V17.

<sup>b</sup> Maximum capacity is obtained using VXA-320 (VXA-3) format; assumes the host computer keeps the tape drive streaming.

<sup>c</sup> One gigabyte equals 1,000,000,000 bytes.

<sup>d</sup> Assumes a 2:1 compression ratio. Actual compressed capacity varies depending on the type of data being recorded. The VXA-320 tape drive uses the ALDC (Adaptive Lossless Data Compression) algorithm and integrated circuit chip. The ALDC algorithm is compliant with the European Computer Manufacturers Association (ECMA) standard. Data compression is controlled by the software application. Enabling or disabling the tape drive's hardware compression is controlled by the backup application.

## PERFORMANCE SPECIFICATIONS

This section describes the performance specifications for the tape drive. The tape drives are factory tested to these specifications using VXAtape XTape media.

### DATA TRANSFER RATES

Table 7-2 lists the data transfer rates that the High-density, LVD tape drive can achieve.

**Table 7-2** Data transfer rates in megabytes per second

Read <sup>a, b</sup>		Write <sup>a, b</sup>		Burst transfer rate	
VXA-3 Format	VXA-2 Format	VXA-3 Format	VXA-2 Format	VXA-3 Format	VXA-2 Format
12.0 MB/sec <sup>c</sup>	6.0 MB/sec	12.0 MB/sec	4.5 MB/sec	160 MB/sec	160 MB/sec

<sup>a</sup> Host matching.

<sup>b</sup> When attached to a High-density LVD SCSI bus. All sustained data rates are dependent on the capabilities of the SCSI bus (for example, an Ultra2 SCSI bus is limited to less than 40 MB/second).

<sup>c</sup> One megabyte equals 1,000,000 bytes.

### READ AND WRITE SPECIFICATIONS

Table 7-3 provides read and write specifications for the VXA-320 tape drive.

**Table 7-3** Read and write specifications

<b>Backward compatibility with VXA-1 and VXA-2 tape drives<sup>a</sup></b>	<ul style="list-style-type: none"> <li>▪ Reads and writes VXA XTape written by a VXA-2 tape drive.</li> <li>▪ Recognizes, then ejects VXA-1 formatted tapes.</li> <li>▪ Recognizes, then ejects VXAtape V6, V10, and V17<sup>b</sup>.</li> </ul>
<b>Compression</b>	ALDC (Adaptive Lossless Data Compression)
<b>Bit error rate</b>	Less than $1 \times 10^{-17}$
<b>Partitions</b>	2
<b>Buffer</b>	8 megabytes (MB)
<b>Error detection and correction</b>	4 layer Reed Solomon
<b>Format</b>	Discrete Packet Format
<b>Heads (8)</b>	<ul style="list-style-type: none"> <li>▪ 4 write heads</li> <li>▪ 4 read/write check/read heads</li> </ul>
<b>Data media</b>	<ul style="list-style-type: none"> <li>▪ VXAtape cartridges with Advanced Metal Evaporated (AME) media. The tape drive ejects other types of media.</li> <li>▪ No formatting or conditioning required prior to use.</li> <li>▪ 30-year archival life.</li> </ul>

<sup>a</sup> The VXA-320 (VXA-3) tape drive can read or write VXA-2 formatted V23, X23, X10, or X6 tapes.

<sup>b</sup> The VXA-320 (VXA-3) tape drive does not support VXAtape V6, V10, or V17.

## TAPE SPEED AND ACCESS TIME

The time required to move the tape to a specified position depends on the operation being performed. [Table 7-4](#) lists the tape speeds and access times for the VXA-320 tape drive.

**Table 7-4** Tape speed and access times

<b>Search speed (maximum)</b>	165 x read/write speed (1 GB/second, native)
<b>Mid-tape reposition time (average)<sup>a, b</sup></b>	X6 cartridge: 75 seconds X10 cartridge: 75 seconds X23 or V23 <sup>c</sup> cartridge: 120 seconds
<b>Load time (logical)</b>	45 seconds for an initialized tape 50 seconds for an uninitialized tape
<b>Unload time (logical)</b>	65 seconds
<b>Tape speed</b>	17.90 mm/second (typical)

<sup>a</sup> In addition to maximum search speed, the mid-tape reposition times depend on acceleration, deceleration, and read positioning to location.

<sup>b</sup> The VXA-320 tape drive does not support VXAtape V6, V10, or V17.

<sup>c</sup> The VXA-320 tape drive can read or write VXA-2 formatted V23 tapes.

## RELIABILITY SPECIFICATIONS

[Table 7-5](#) provides reliability specifications for the VXA-320 tape drive.

**Table 7-5** Reliability specifications

<b>Mean Time Between Failures (MTBF)</b>	300,000 hours
<b>Mean Time to Repair (MTTR)</b>	30 minutes
<b>Service life</b>	5 years
<b>Write reliability</b>	Bit error rate of less than $1 \times 10^{-16}$
<b>Read reliability</b>	Bit error rate of less than $1 \times 10^{-17}$
<b>Loads/unloads</b>	50,000 cycles, minimum

## SIZE AND WEIGHT

Table 7-6 shows the dimensions and width for the internal and external tape drives. The internal tape drive is a 5.25-inch form factor tape drive for integration into an enclosure. The external tape drive is a standalone unit that can fit on a desktop.

**Table 7-6** Size and weight

Specification	Internal Tape Drive	External Tape Drive
Depth	41.5 mm (1.63 in)	86.0 mm (3.38 in)
Depth (with bezel)	42.6 mm (1.68 in)	
Length	203.0 mm (8.0 in)	285.0 mm (11.25 in)
Width	146.0 mm (5.75 in)	227.0 mm (8.93 in)
Width (with bezel)	149.2 mm (5.87 in)	
Weight	1.0 kg (2.2 lbs)	3.0 kg (6.6 lbs)

Figure 7-1 shows the dimensions of the internal tape drive. Figure 7-2 shows the dimensions of the external tape drive.

**Note:** Dimensions are shown in millimeters with inches in parenthesis.

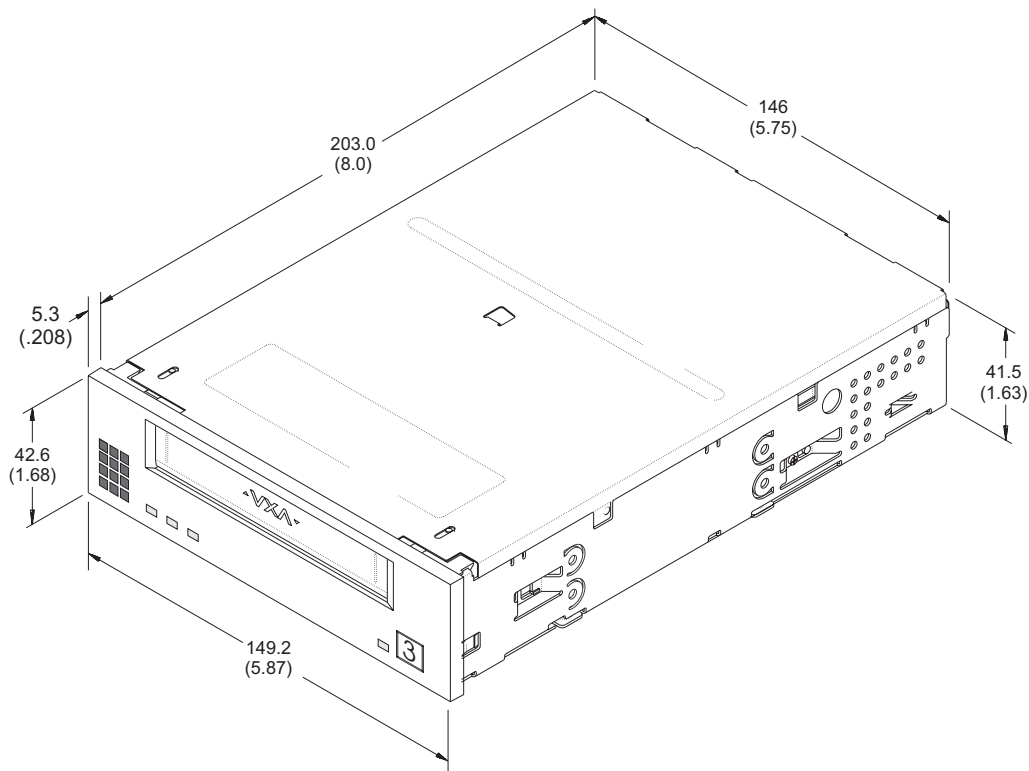

**Figure 7-1** Physical dimensions of the internal tape drive

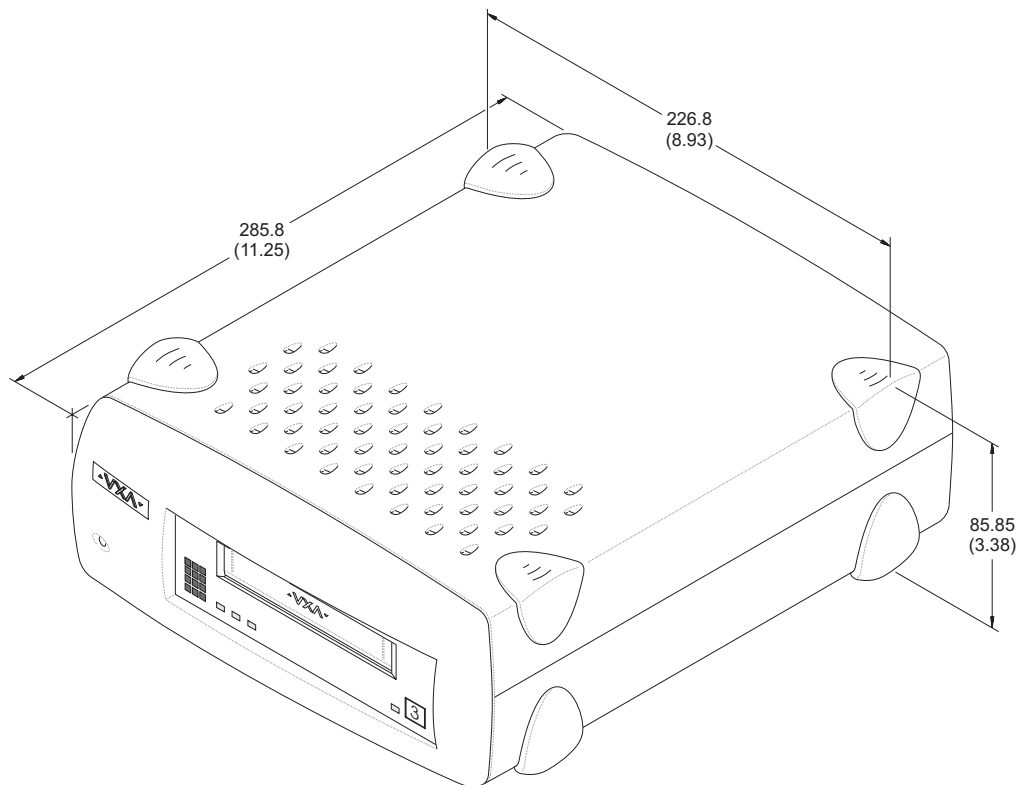

**Figure 7-2** Physical dimensions of the external tape drive

## POWER SPECIFICATIONS

This section lists the power specifications for the VXA-320 tape drive.

### INTERNAL TAPE DRIVE

The power specifications listed in this section are in addition to any requirements for the enclosure in which it is installed.

#### Power Connector Pin Assignments

The VXA-320 power connector is compatible with power cables used for standard 5.25-inch half-high devices. The enclosure's power cable connector must be an AMP 1-480424-0 series, or equivalent. [Table 7-7](#) provides pin assignments for the tape drive's power connector.

**Table 7-7** Pin assignments for the power connector

Pin	Assignment
1	+12 VDC
2	Ground, 12 VDC return
3	Ground, 5 VDC return
4	+5 VDC

## DC Voltages

The internal tape drive operates from standard +5 and +12 VDC supply voltages (all specified voltages are DC, no external AC power is used).

**Note:** The VXA-320 tape drive does not provide overvoltage or overcurrent protection, except for TERMPWR, which has a resettable fuse. Safety agency certifications are based on the voltages being supplied by a Safety Extra Low Voltage (SELV) source (per IEC 950).

**Table 7-8** Power specifications (internal model)

Power	+5 Volts		+12 Volts	
Required supply tolerance:	±5%		±10%	
Ripple and noise: (50 Hz to 20 MHz) <sup>a</sup>	250 mVpp max.		250 mVpp max.	
Operating current (amps)				
Read or write:	1.25 (average)	1.27 (peak)	0.51 (average)	0.57 (peak)
Search/high speed:	1.11 (average)	1.22 (peak)	0.59 (average)	2.00 (peak)
Load/unload:	1.00 (average)	1.20 (peak)	0.45 (average)	2.00 (peak)
Power up:	0.90 (average)	1.17 (peak)	0.08 (average)	0.44 (peak)
Idle:	0.83 (average)	—	0.06 (average)	—

<sup>a</sup> The ripple voltage is included in the total voltage tolerance.

## Power Consumption

Table 7-9 shows the internal tape drive's power consumption when operating and when idle.

**Table 7-9** Power consumption (internal model)

Power Consumption	Power (average)
Read or write:	12.4 watts
Search/high speed:	12.7 watts
Load/unload:	10.4 watts
Power up:	5.5 watts
Idle:	4.9 watts

## EXTERNAL TAPE DRIVE

The power specifications for the external tape drive include both the requirements for the tape drive and the enclosure components.

## Power Supply

The external tape drive uses an internal switching power supply. Do not change any input settings. The power supply automatically adjusts for changes in voltages and frequency within the specified range.

**Table 7-10** Power supply specifications (external model)

<b>Type</b>	40 watts, switching
<b>Efficiency</b>	70% minimum
<b>Input voltage<sup>a</sup></b>	90 – 276 VAC
<b>Frequency</b>	47 – 63 Hz

<sup>a</sup> Autoswitching input selection; no user selection required.

## Power Consumption

Table 7-11 provides power consumption specifications.

**Table 7-11** Power consumption (external model)

<b>AC input current</b>	0.5 amp @ 115 VAC 0.25 amp @ 230 VAC
-------------------------	---

## ACOUSTIC NOISE

Internal tape drive—

**Table 7-12** Acoustic noise specifications (internal tape drive)

<b>Operating Mode</b>	<b>L<sub>pA</sub><sup>a</sup></b>
Powered on, idle	40 L <sub>pA</sub>
Read or write	42 L <sub>pA</sub>
High-speed search or rewind (up to 2-minute duration)	42 L <sub>pA</sub>

<sup>a</sup> The average A-weighted sound pressure level over the frequency range 5 Hz – 12.5 kHz.

External tape drive—When measured in the external enclosure, these levels do not exceed the upper limits specified in the table.

**Table 7-13** Acoustic noise specifications (external tape drive)

<b>Operating Mode</b>	<b>L<sub>pA</sub><sup>a</sup></b>
Powered on, idle	40 L <sub>pA</sub>
Read or write	43 L <sub>pA</sub>
High-speed search or rewind (up to 2-minute duration)	43 L <sub>pA</sub>

<sup>a</sup> The 30-second sustained average A-weighted sound pressure level over the following frequency range: 5 Hz to 12.5 kHz.

## ENVIRONMENTAL SPECIFICATIONS

This section lists the environmental specifications for the tape drive and the cartridges.

### ENVIRONMENTAL CONDITIONS FOR THE TAPE DRIVE

Table 7-14 summarizes the environmental requirements for the tape path in either the internal or external models of the tape drive. The following sections provide additional detail about these requirements.

**Table 7-14** Temperature and humidity specifications for the tape drive

Specification	Operating <sup>a,b</sup>	Storage <sup>c</sup> / Nonoperating	Transporting <sup>c</sup>
Temperature range	+5°C to +45°C (+41°F to +113°F)	-40°C to +60°C (-40°F to +140°F)	
Temperature variation	1°C per min; max 10°C per hour (2°F per min; max 18°F per hour)	1°C per min; max 20°C per hour (2°F per min; max 36°F per hour)	
Relative Humidity	20% to 80% non-condensing	5% to 95% non-condensing	
Wet bulb	29°C (84.2°F) max.	N/A	
Altitude	-304.8 to +3,048 m (-1,000 to +10,000 ft)		-304.8 to +12,192 m (-1,000 to +40,000 ft)

<sup>a</sup> The tape drive temperature and humidity must be stabilized in the specified environment for at least 24 hours.

<sup>b</sup> Temperature measurements are made in the tape path.

<sup>c</sup> The tape drive is in its original shipping container. When the tape drive is moved from a cooler storage environment to a warmer operating environment, it must acclimate in its packaging for 24 hours to prevent damage from condensation.

### Internal Tape Drive: Operating Temperature and Humidity

Figure 7-3 provides the temperature and humidity requirements for the internal tape drive. The area within the dotted line represents the operating environment. Table 7-15 defines the points in the chart.



**Caution**

The operating temperature and humidity specifications are for the tape path. When the tape drive is in an enclosure, the ambient temperature typically must be lower than the maximum temperature to avoid exceeding the maximum at the tape path.

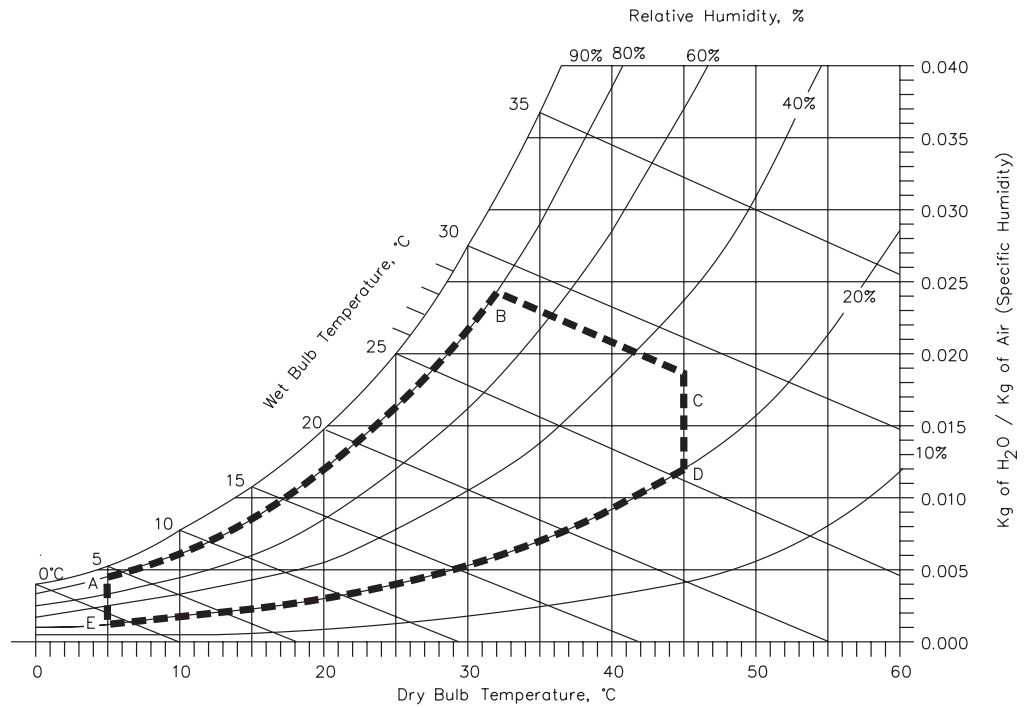

**Figure 7-3** Internal model: Operating temperature and humidity ranges

**Table 7-15** Internal model: Operating temperature and humidity points

Point	Temperatures	Humidity
A	5°C	80%
B	32°C	80%
C	45°C	32%
D	45°C	20%
E	5°C	20%

### External Tape Drive: Operating Temperature and Humidity

Figure 7-4 provides the ambient temperature and humidity requirements for the external tape drive. The area within the dotted line represents the operating environment. Table 7-16 defines the points on the chart. Operation of the external tape drive within these requirements will maintain the proper tape path temperature of the tape drive.

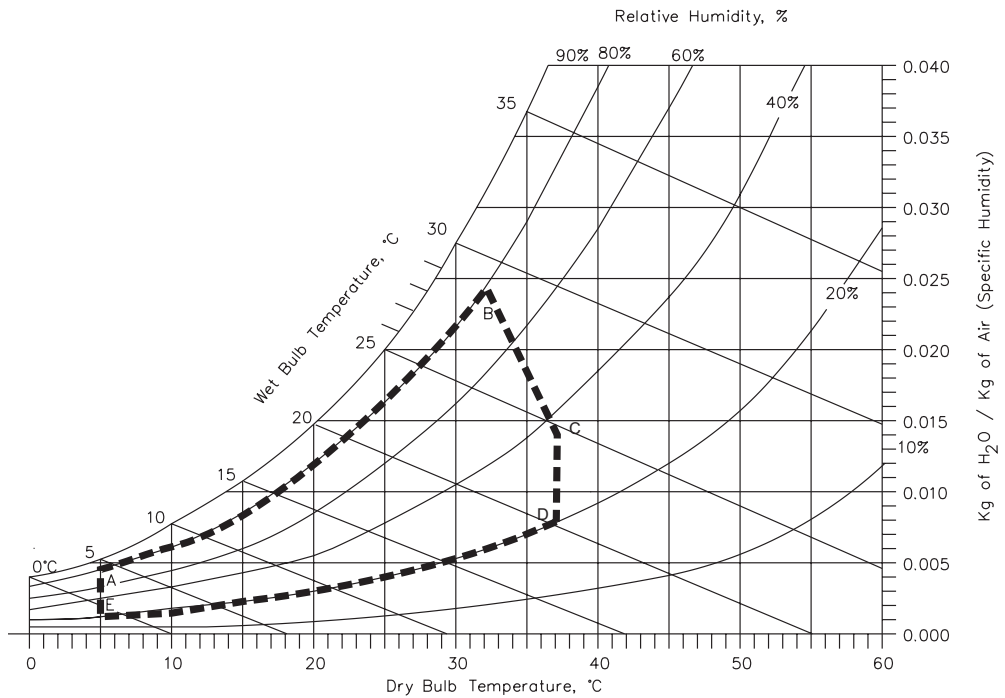

Figure 7-4 External model: Ambient operating temperature and humidity ranges

Table 7-16 External model: Operating temperature and humidity points

Point	Temperatures	Humidity
A	5° C	80%
B	32° C	80%
C	37° C	32%
D	37° C	20%
E	5° C	20%

## Air Flow/Cooling Requirements

When mounted in the host enclosure, the tape drive must have adequate air flow. Ensure that ambient air is allowed to pass through the ventilation holes shown in [Figure 3-1 on page 19](#). These ventilation holes must not be blocked. The air flow around the tape drive must be sufficient to prevent tape path temperatures from exceeding 45 °C (113 °F).

The tape drive is equipped with a temperature sensor. It issues an overtemperature signal through the LOG SENSE command if the above temperature is exceeded. You can access temperature data through the LOG SENSE command. See the *VXA-320 (VXA-3) SCSI Reference Manual*.

## Particulate Contamination Limits

The VXA-320 tape drive is designed to operate in environments that do not exceed the limits listed in [Table 7-17](#).

**Table 7-17** Particulate contamination limits

Particle Size (Microns)	Number of Particles $\geq$ Particle Size per Cubic Meter	Number of Particles $\geq$ Particle Size per Cubic Foot
0.1	$8.8 \times 10^7$	$2.5 \times 10^6$
0.5	$3.5 \times 10^7$	$1.0 \times 10^6$
5.0	$2.5 \times 10^7$	$7.0 \times 10^6$

## Shock Specifications

The storage and nonoperating shock levels indicate how much shock the tape drive can withstand when it is not operating. The operating shock levels indicate how much shock the tape drive can withstand while reading and writing data. After withstanding this amount of shock, the tape drive operates normally.

[Table 7-18](#) lists the shock specifications for the tape drive.

**Table 7-18** Shock specifications

Operating	Nonoperating <sup>a, b</sup>	Transportation <sup>c</sup>
5 g for 3 msec <sup>d</sup> 6 g for 11msec <sup>e</sup>	60 g for 3 msec 50 g for 11 msec	ISTA Procedure 2A

<sup>a</sup> The tape drive has been unpacked, but no power is applied.

<sup>b</sup> Half-sine shock pulses are applied to each of the three orthogonal axes. (Three shocks at 60 g at a rate not exceeding 1 shock per second. One shock at 50 g.)

<sup>c</sup> The tape drive is in its original shipping container.

<sup>d</sup> Half-sine, at a rate not exceeding 1 shock per second; 20 shocks applied to each of the three orthogonal axes.

<sup>e</sup> Half-sine, at a rate not exceeding 1 shock per every 3 seconds; 10 shocks applied to each of the three orthogonal axes.

## Vibration Specifications

Table 7-19 lists the operating specifications that indicate the amount of vibration the tape drive can withstand while reading and writing data.

**Table 7-19** *Vibration specifications*

Random vibration <sup>a</sup> applied during operation (reading and writing)	
10 Hz to 500 Hz	PSD = 0.0005102 g <sup>2</sup> /Hz
Random vibration <sup>b</sup> applied during non-operation (unpacked) and storage (in original packaging)	
1 Hz to 400 Hz	
Vibration applied during shipping (in original packaging)	
ISTA Procedure 2A	
Swept sine applied during non-operation <sup>c</sup> and operating <sup>d</sup>	
5 to 500 to 5 Hz <sup>c</sup> 10 to 500 Hz <sup>d</sup>	

<sup>a</sup> A 0.5 Grms random vibration spectrum is applied to each of three orthogonal axes for a minimum of 30 minutes per axis.

<sup>b</sup> A 1.06 Grms random vibration spectrum is applied to each of three orthogonal axes for a minimum of 20 minutes per axis.

<sup>c</sup> Three sweeps at one octave per minute are applied to each axis at 0.75 g (peak) input.

<sup>d</sup> One sweep at one-quarter octave per minute are applied to each axis at 0.5 g (peak) input.

## ENVIRONMENTAL CONDITIONS FOR THE VXATAPE CARTRIDGES

Table 7-20 summarizes the environmental requirements for the VXAtape cartridges. You should maintain the temperature and humidity at a steady level within these ranges, and also limit fluctuations in temperature and humidity.

**Note:** When a VXAtape is brought into the room where the VXA tape drive is located, allow the VXAtape to adjust to room temperature and humidity before using it.

**Table 7-20** *Temperature and humidity specifications for the VXAtape cartridges*

Specification	Storage <sup>a</sup> / Nonoperating	Transporting <sup>a</sup>
Temperature range	+5°C to +32°C (+41°F to +90°F)	−40°C to +45°C (−40°F to +113°F)
Temperature variation	1°C per min; max. 20°C per hour (2°F per min; max. 36°F per hour)	
Relative humidity	20% to 60% non-condensing	5% to 80% non-condensing

**Table 7-20** Temperature and humidity specifications for the VXA tape cartridges

Specification	Storage <sup>a</sup> / Nonoperating	Transporting <sup>a</sup>
Wet bulb	26°C (79°F) max.	
Altitude	-304.8 to +3,048 m (-1,000 to +10,000 ft)	-304.8 to 12,192 m (-1,000 to 40,000 ft)

<sup>a</sup> The cartridge is in its original packaging. When the cartridge is moved from a cooler storage environment to a warmer operating environment, it must acclimate in its packaging for 24 hours to prevent damage from condensation.

## PACKAGING AND SHIPPING SPECIFICATIONS

This section describes the packaging and shipping requirements for the tape drive.

### SHIPPING CARTONS

The tape drive is sealed in a static protection bag and shipped in a single-pack or multi-pack carton. [Table 7-21](#) lists the weights and dimensions of the shipping cartons.

**Table 7-21** Shipping carton weights and dimensions

Carton	Weight	Dimensions
<b>Single Pack</b>		
Internal Tape Drive	3 lbs, 4 oz (1.5 kg)	Length: 13.5 in. (34.3 cm) Width: 10.75 in. (27.3 cm) Depth: 8.5 in. (21.6 cm)
External Tape Drive	12 lbs (5.4 kg)	Length: 21 in. (53.3 cm) Width: 15 in. (38.1 cm) Depth: 6.5 in. (16.5 cm)
<b>Multipack: 10 Internal Tape Drives</b>		
10 Tape Drives	25.5 lbs (11.6 kg)	Length: 21.5 in. (54.6 cm) Width: 16 in. (40.6 cm) Depth: 14.5 in. (36.8 cm)

The shipping cartons and internal packing materials are designed so that the enclosed tape drive does not receive a damaging shock when the carton is dropped on any surface, corner, or edge from a height of:

- ▶ Single-pack: 48 in. (121.9 cm), at a velocity change of 192 in./sec (488 cm/sec)
- ▶ Multipack: 36 in. (91.4 cm), at a velocity change of 167 in./sec (424 cm/sec)

## PACKAGING MATERIALS

The tape drive's packing materials are unbleached, reusable, recyclable, and environmentally safe. The materials contain no chlorofluorocarbons (CFCs) or heavy metals. The shipping cartons pass the tests described in the International Safe Transit Association (ISTA) Procedure 2A.

## SAFETY AND REGULATORY COMPLIANCE

The VXA-320 (VXA-3) tape drive complies with the regulatory agency standards listed below when installed in accordance with this manual.

The system integrator is responsible for the certification and verification of the final product into which the VXA-320 (VXA-3) tape drive is integrated, with the relevant product safety, and EMI and EMC standards.

### UNDERWRITERS LABORATORY



The internal configuration has been evaluated by UL for use in listed finished products. Construction or performance of these components may not warrant listing of the devices on their own. Recognized components may be used in listed products, provided that they are applied within the conditions of acceptability stated in the report.



The external configuration of the VXA-320 (VXA-3) tape drive is listed by Underwriters Laboratories, Inc. Representative samples of this product have been evaluated by UL and meet the applicable U.S. and Canadian safety standards.

### TUV PRODUCT SERVICE



Signifies that the VXA-320 (VXA-3) internal tape drive has been tested in accordance with EN 60950-1:2001 and has met the applicable product safety requirements.



The TÜV Mark for the VXA-320 (VXA-3) external tape drive demonstrates that it has met the requirements of EN 60950-1:2001.

## UNITED STATES: FCC DECLARATION OF CONFORMITY



We declare under our sole responsibility that:

Product Name: VXA-320 (VXA-3) Tape Drive

Model Numbers: VXA-320i (internal); VXA-320e (external)

Product Options: All

To which this declaration relates, is in conformity with the following standard(s) or other normative documents:

ANSI C63.4-1992 Methods of Measurement

Federal Communications Commission 47 CFR Part 15, Subpart B

15.107 (a) Class B Conducted Limits

15.109 (a) Class B Radiated Emission Limits

This device complies with Part 15 of the FCC Rules. Operation is subject to the following two conditions: (1) This device may not cause harmful interference, and (2) This device must accept any interference received, including interference that may cause undesired operation.

**Note:** This equipment has been tested and found to comply with the limits for a Class B digital device, pursuant to part 15 of the FCC Rules. These limits are designed to provide reasonable protection against harmful interference in a residential installation. This equipment generates, uses and can radiate radio frequency energy and, if not installed and used in accordance with the instructions, may cause harmful interference to radio communications. However, there is no guarantee that interference will not occur in a particular installation.

If this equipment does cause harmful interference to radio or television reception, which can be determined by turning the equipment off and on, the user is encouraged to try to correct the interference by one or more of the following measures:

- Reorient or relocate the receiving antenna.
- Increase the separation between the equipment and receiver.
- Connect the equipment into an outlet on a circuit different from that to which the receiver is connected.
- Consult the dealer or an experienced radio/TV technician for help.
- Shielded cables are required for this device to comply with FCC Rules. Use shielded cables when connecting this device to others.

## CANADIAN VERIFICATION



This Class B digital apparatus complies with ICES-003.

Cet appareil numérique de la classe B est conforme à la norme NMB-003 du Canada.

## EUROPEAN COMMUNITY



This Information Technology Equipment has been tested and found to comply with the following European directives:

(1) EMC Directive 89/336/EEC, amended by directive 93/68/EEC, according to:

EN55022

EN55024

EN61000-3-2

EN61000-3-3

(2) Low Voltage Directive 73/23/EEC, amended by directive 93/68/EEC, according to: EN60950-1:2001

## JAPAN



This equipment is Class B (Information Technology Equipment to be used in a residential area or an adjacent area thereto) and conforms to the standards set by the Voluntary Control Council for Interference (VCCI) by Information Technology Equipment aimed at preventing radio interference in such residential area.

When used near a radio or TV receiver, it may become the cause of radio interference. Read instructions for correct handling.

## AUSTRALIA AND NEW ZEALAND



This device has been tested and found to comply with the limits for a Class B digital device, pursuant to the Australian/New Zealand standard AS/NZS 3548 set out by the Australian Communications Agency.

## TAIWAN

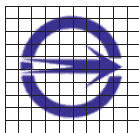

This device has been tested and found to comply with standard CNS 13438, Class B for Electromagnetic Compatibility (EMC) as established by the Taiwan Ministry of Economic Affairs (MOEA), Bureau of Standards, Metrology and Inspection (BSMI).

## RESTRICTION OF HAZARDOUS SUBSTANCES IN ELECTRICAL AND ELECTRONIC EQUIPMENT (ROHS)



The VXA-320 (VXA-3) internal tape drive is in compliance with European Council Directive 2002/95/EC, on the restriction of the use of certain hazardous substances in electrical and electronic equipment.

The VXA-320 (VXA-3) external tape drive will be in compliance with this Directive, prior to the July 1, 2006 deadline.

## WASTE OF ELECTRONIC AND ELECTRICAL EQUIPMENT (WEEE)



This device is in compliance with 2002/96/EC Waste of Electronic and Electrical Equipment (WEEE).

# G

## GLOSSARY

### A

**Adaptive Lossless Data Compression (ALDC)** An advanced data compression algorithm that provides an average compression ratio of 2:1 across multiple data types. *See also* [Compression](#).

**Advanced Metal Evaporated (AME) media** A state-of-the-art tape technology designed for data storage. VXAtape cartridges use AME media.

**American National Standards Institute (ANSI)** Organization that sets standards for SCSI and the safety of electrical devices.

### B

**Bit error rate (BER)** The probability that a transmitted bit will be received in error. The BER is expressed as a ratio of error bits to total number of bits.

**Buffer** A temporary storage area, usually in Random Access Memory (RAM). The tape drive's read and write buffers act as holding areas that enable the tape drive to balance the rate at which it transfers data to or from tape with the data transfer rate of the host. The VXA-320 tape drive has a 16-MB buffer.

**Bus** In a network, the electrical pathway between a computer and other devices.

### C

**CAW-After-Write (CAW)** A process that improves data integrity by reading data immediately after it is written and writing the packet again if an error is found. Individual packets are rewritten as necessary, optimizing speed and capacity.

**Compression** The reduction in size of data to save space. Either the backup application or the tape drive can perform compression. *See also* [Adaptive Lossless Data Compression \(ALDC\)](#).

**Cyclic redundancy check (CRC)** The error detection technique that checks for uncorrected data during a read operation.

**D**

**Data Transfer Rate** The speed that data can be transmitted from one device to another. Data rates are often measured in megabits (million bits) or megabytes (million bytes) per second.

**Discrete Packet Format (DPF)** The format used by the VXA-320 (VXA-3) tape drive to read and write data in packet form. Data packets also contain a synchronization marker, unique address information, CRC, and ECC.

**Driver** A program that works with a computer's operating system to operate a peripheral device. Also referred to as a "device driver."

**E**

**End of data (EOD)** In a partition, a special format group that is written after all current user data is transferred to the tape.

**Error correction code (ECC)** Error correction codes are generated within the tape drive and recorded with the user data. ECC is used to correct the errors in the user data while being read.

**Exabyte** (1) A network storage backup company that designs, manufactures, and markets industry-leading data storage products including tape drives and automated tape libraries.

(2) measurement of data:

One Exabyte = 1,000 Petabytes, or  
1,000,000 Terabytes, or  
1,000,000,000 Gigabytes, or  
1,000,000,000,000 Megabytes, or  
1,000,000,000,000,000 Kilobytes, or  
1,000,000,000,000,000,000 bytes

**F**

**Filemark** A mark on the tape, which is written by the tape drive. A filemark consists of a special recorded element within a partition, containing no user data, which provides a segmentation or location scheme for the data on the tape. Filemarks are typically used during a locate or space operation to move to a particular spot on the tape.

**G**

**Gigabyte** One billion bytes.

**H**

**Head** A device that uses induction to write a data pattern onto magnetic media and then uses either inductance or magnetoresistance to read the data back.

**Host** Any type of computer that sends information or commands to a peripheral device, such as the tape drive.

**I**

**Initiator** A SCSI device containing application clients that originate device service requests to be processed in a device server. The host typically acts as the initiator of commands.

**L**

**LED** Light Emitting Diode. The indicators on the front panel of the tape drive.

**Load** The process of inserting a cartridge into the tape drive. The tape drive automatically loads the tape into the tape path.

**Low Voltage Differential (LVD)** A differential SCSI interface that allows bus lengths up to 12 meters, transfer rates up to 160 MB/sec., and allows single-ended devices to co-exist on the bus.

**M**

**msec** Millisecond; one-thousandth of a second.

**Mean Time Between Failures (MTBF)** A quantitative measure used to specify the reliability of a tape drive's mechanics and electronics as a whole under specific environmental conditions, cleanings, and duty cycle.

**Megabyte** One million bytes.

**N**

**Noise** Any kind of magnetic or electric interference detected by the electronics.

**O**

**OverScan Operation (OSO)** The VXA technique for reading data packets independently of track shape or geometry. By reading packets with multiple scans, OSO ensures that each packet is read at least once.

**P**

**Packet** The basic VXA format structure that includes data, ECC, and address and synchronization information.

**Partition** A self-contained area on a tape that can be written and read independently to make more efficient use of the media. The VXA-320 (VXA-3) tape drive accommodates two partitions.

**Peripheral Device** Any device attached externally to a computer as an optional device, such as tape drives, printers, scanners, and so forth.

**Power Cycle** (1) Turn the tape drive off, wait for 10 seconds, then turn the tape drive back on. Wait for the tape drive to go through its Power-on Self-test (POST).

(2) If you are required to power cycle the tape drive due to overheating, allow it to cool for several minutes before turning it back on (see [“LED 4 is Flashing Orange” on page 26](#) for additional information).

**R**

**RAID Controller** A Redundant Array of Independent Disks Controller is a collection of disk drives that employs two or more drives in combination for fault tolerance and performance.

**Read-After-Write (RAW)** A process that improves data integrity by reading data immediately after it is written and writing the packet again if an error is found. Individual packets are rewritten as necessary, optimizing speed and capacity.

**RoHS** The RoHS Directive mandates that electrical and electronic products put in the market within the European Union (EU) shall contain restrictive levels of the following substances:

- ▶ Lead (Pb)
- ▶ Cadmium (Cd)
- ▶ Mercury (Hg)
- ▶ Hexavalent Chromium (Cr6+)
- ▶ Polybrominated Biphenyls (PBB)
- ▶ Polybrominated Diphenyl Ethers (PBDE)

**S**

**SCSI** Small Computer System Interface. A device interface that has been certified as an American National Standard by ANSI. The standard contains the electrical specifications, communication protocol, and command structure necessary to connect various computer peripherals to a host computer.

**SCSI ID** A unique address assigned to each device attached to a SCSI bus. *See also* [Bus](#).

**Segment** The format structures contained within the data buffer. Each segment contains 1,220 packets of data, ECC, and CRC information.

**Setmark** A mark written by the tape drive to allow fast searching to a point on the tape without having to know the number of records or filemarks that precede the point. A setmark is a special recorded element within a partition, that contains no user data, and provides a segmentation scheme hierarchically superior to filemarks for use in addressing or fast positioning on high-capacity storage devices (also called Save-Set Mark).

**Streaming** An operational mode that occurs when the data transfer rate to or from the host closely matches the tape drive's data transfer rate, allowing the tape drive to read or write data in a continuous stream.

**T**

**Termination** In SCSI, termination refers to placing a resistor (terminator) at both physical ends of the SCSI bus to prevent signal reflection.

**Transfer rate** The transmission speed of a communications line. The tape drive transfer rates are measured in megabytes per second (MB/sec).

**V**

**Variable Speed Operation (VSO)** The VXA technique for adjusting tape motion to match the host transfer rate, eliminating “backhitching.” This technique optimizes backup and restore times, while enhancing media and tape drive reliability.

**Volume** A recording medium together with its physical carrier (a single tape cartridge).

**VXA** VXA is a breakthrough tape technology that offers previously unobtainable levels of reliability, data availability and interchange, and recoverability, capacity and interchangeability. This is accomplished through the exclusive combination of OverScan Operation (OSO), Variable Speed Operation (VSO) and Discrete Packet Format (DPF).

**VXATool** A diagnostic program used on the host computer to configure, troubleshoot, and upgrade firmware in the VXA-320 (VXA-3) tape drive over the tape drive’s SCSI interface.

## NOTES

# INDEX

## A

- AC power connector, location 4
- acoustic noise 55
- agency declarations
  - Australian Communications Agency 64
  - Bureau of Standards, Metrology and Inspection (BSMI) 64
  - Canadian Verification 63
  - European Community 64
  - FCC 63
  - RoHS 64
  - TUV Product Service 62
  - Underwriters Laboratory 62
  - Voluntary Control Council for Interference (VCCI) 64
  - WEEE 64
- agency labels 5, 62 to 64
- air flow requirements 59
- ALDC compression algorithm 50
- altitude specifications 56
  - VXAtape cartridge 61
- AME media 50
  - See also* cartridges
- application software
  - See* backup application
- archival life, media 23, 50
- auxiliary connector (internal tape drive), location 3

## B

- backup application
  - compatibility 18
  - integrating the tape drive 18
  - tape drive problems 27
- backup software
  - preparing for installation 9, 14

- backward compatibility 50
- bezel components 2
- bit error rate 50 to 51
- buffer size 50
- Bus Device Reset
  - See* messages, Target Reset
- bus phases 38

## C

- capacities 49
- cartons, shipping 61
- cartridges
  - archival life 23, 50
  - capacities 49
  - cleaning 23
  - compatibility 50
  - loading 22
  - operating environment 60
  - retiring 23
  - setting the write-protect switch 22
  - specifications 50
  - tape drive does not accept cartridge 25
  - tape drive does not eject cartridge 27
  - unloading 22
  - using 22
- chassis grounding 3, 10
- cleaning
  - instructions 23
  - LED indicators 20, 23
- cleaning wheel 23
- command protocol, definition 37
- commands supported, SCSI 44 to 45
  - See also* SCSI commands
- communication interface
  - definition 37
  - SCSI message system 39 to 40

compatibility  
 with previous VXA generations 50  
 with software and operating systems 18

compliance, safety and regulatory 62 to 64

components, back panel  
 external SCSI model 4  
 internal tape drive 3

components, front panel 2

compression 50

connectors, back panel  
 external tape drive 4  
 internal tape drive 3  
*See also* AC power connector  
*See also* auxiliary connector  
*See also* power connector  
*See also* SCSI connectors  
*See also* serial connector

cooling 59

## D

data capacities 49

data transfer rate 50

DC voltages 54

device drivers 18

diagnostic port, location (external model) 4

diagnostics, performing 31, 36

dimensions 52 to 53

Discrete Packet Format 50

door  
 loading a cartridge 22  
 location 2

drive bay, installing the SCSI tape drive 8 to 13

## E

eject button  
 doesn't eject cartridge 27  
 location 2  
 using to eject cartridge 22

enclosure, installing the SCSI tape drive 8 to 13

environmental specifications 56 to 60

error  
 LED indicators 20  
 reported in software 29 to 30

error detection and correction 50

error rate 50 to 51

error recovery procedures, for Service Notification LEDs 28 to 29

ESD protection 10

Extended Messages (01h) message  
 Parallel Protocol Request (04h) 39  
 Synchronous Data Transfer Request (01h) 39  
 Wide Data Transfer Request (03h) 39

external tape drive, installing the SCSI tape drive 14 to 16

## F

Fast-80 DT SCSI  
*See* High-density (HD) SCSI

firmware, upgrading 36

form factor 52

format, read and write 50

front panel  
*See* components, front panel

## G

grounding hole and tab (internal model)  
 location 3  
 using to ground tape drive 10

## H

heads, read/write 50

High-density (HD)  
 SCSI interface requirements 40 to 43  
 transfer rates 50

host bus adapter, Ultra160 SCSI 8, 14

humidity, specifications  
 tape drive 56 to 58  
 VXA tape cartridges 60

## I

ID switch  
*See* SCSI ID switch

installing backup software 9, 14

installing software 18

integrating the tape drive into a system 18

internal tape drive, installing 8 to 13

## J

jumpers

using to set SCSI ID 10  
*See also* SCSI ID jumper block

**L**

## labels

agency 62 to 64  
 identification and configuration 5

## LEDs

cleaning indicator 23  
 definition of all states 20 to 21  
 location 3  
 over-temperature indicator 21, 26  
 power-on sequence 13, 16  
 service indicator 20

load cycles specification 51

load/unload time 51

**M**

mean time between failures (MTBF) 51

mean time to repair (MTTR) 51

## media

*See* cartridges

## messages

Abort Task Set (06h) message 40  
 Disconnect (04h) message 39  
 Extended Messages (01h) 39  
 Identify (80h or C0h) message 40  
 Ignore Wide Residue (23h) 40  
 Initiator Detected Error (05h) message 39  
 Message Parity Error (09h) message 40  
 Message Reject (07h) message 40  
 No Operation (08h) message 40  
 Restore Pointers (03h) message 39  
 Save Data Pointers (02h) message 39  
 Target Reset (0Ch) message 40  
 Task Complete (00h) message 39

mid-tape reposition time 51

model number 5

models 1

mounting configurations for the internal  
 model 12

mounting orientation 1, 8

**N**

noise levels 55

**O**

on/off switch

*See* power switch

operating environment 56 to 61

operating system

compatibility 18  
 tape drive problems 27

operating the tape drive 19 to 24

overvoltage protection 54

**P**

packaging specifications 61

packing the tape drive 35

part number for tape drive, locating 5

particulate contamination limits 59

partitions, supported by tape format 50

performance specifications 50

phases, SCSI bus 38

pin assignments

power connector 53  
 SCSI connector 42

POST 13, 16, 20

power cable

connecting to external SCSI tape drive 16  
 connecting to internal tape drive 12

power connector

location (external model) 4  
 location (internal model) 3  
 pin assignments 53

power LED, location (external model) 3

power specifications

AC power consumption, external tape  
 drive 55  
 DC voltages, internal tape drive 54  
 power connector requirements, internal tape  
 drive 53  
 power consumption, internal tape drive 54  
 power supply, external tape drive 55

power switch (external model) 4

product identification, changing for software  
 compatibility 18

**R**

read and write specifications 50

read reliability 51

Reed Solomon error detection 50

- regulatory standards 62 to 64
  - reliability specifications 51
  - reposition time 51
  - resetting the tape drive 24
  - retiring cartridges 23
  - returning tape drive for service 35
  - RF service connector, internal model 3
- S**
- safety and regulatory compliance 62 to 64
  - SCSI bus
    - determining total bus length for internal tape drive 9, 15
    - length restriction 9, 15
    - terminator requirements, external tape drive 43
    - terminator requirements, internal tape drive 43
  - SCSI bus phases 38
  - SCSI bus reset 24
  - SCSI cable
    - connecting to external model 15
    - connecting to internal model 11
    - specifications for external tape drive 43
    - specifications for internal tape drive 41
  - SCSI command protocol
    - overview 44 to 46
    - sense keys 46
    - supported commands 44 to 45
  - SCSI communication interface 40 to 43
  - SCSI connectors
    - High-density (HD) 40
    - location (external tape drive) 4
    - location (internal tape drive) 3
    - pin assignments 42
    - specifications for external tape drive 43
    - specifications for internal tape drive 41 to 42
  - SCSI ID
    - jumper block location (internal model) 3
    - SCSI ID switch location (external) 4
    - setting using SCSI ID jumper block (internal model) 10
    - setting using SCSI ID switch (external model) 15
  - SCSI message system 39 to 40
  - SCSI tape drive
    - cable and connector requirements 41 to 43
    - connector locations (external model) 4
    - connector locations (internal model) 3
    - installing (external model) 14 to 16
    - installing (internal model) 8 to 13
  - SCSI terminator
    - installing, external tape drive 16 to 16
    - installing, internal tape drive 12
    - requirements 43
    - terminating the last device on the bus 12, 15
  - search speed 51
  - sense keys, definitions 46 to 47
  - serial connector, location (external model) 4
  - serial number for tape drive 5
  - service connector, internal model 3
  - service life 51
  - Service Notification LEDs
    - description 20
    - error recovery procedures 28 to 29
  - service, returning tape drive 35
  - shipping specifications 61
  - shipping the tape drive 35
  - shock specifications 59
  - single-ended bus, recommendations against 40
  - size of tape drive 52 to 53
  - software
    - See* backup software
  - sound levels 55
  - specifications for tape drive 49 to 64
  - speed 50
  - status bytes supported 46
  - storage environment
    - cartridges 23
    - tape drive 56
- T**
- Tandberg Data, contacting iv
  - tape
    - See* cartridges
  - tape drive
    - installing 7 to 16
    - integrating 18
    - operating system and software compatibility 18
    - operating temperature and humidity 56 to 58
    - product identification 18
    - SCSI requirements 40

- troubleshooting 25 to 33
- upgrading firmware 36
- tape speed 51
- Technical Support
  - contacting iv
  - gather required information before
    - contacting 32 to 33
- temperature data, stored in tape drive 59
- temperature range specifications
  - tape drive 56 to 58
  - VXAtape cartridges 60
- termination, SCSI bus
  - external tape drive 16 to 16
  - internal tape drive 12
  - terminator requirements 9, 15, 15
- transfer rate 50
- troubleshooting 25 to 33

## U

- Ultra160 SCSI
  - host bus adapter 8, 14
- Ultra3 SCSI
  - See High-density (HD) SCSI
- unload button
  - See eject button
- unload/load time 51

- unpacking 7
- upgrading firmware 36

## V

- vibration specifications 60
- voltage specifications 55
- voltages, DC power 54
- VXA-1 compatibility 50
- VXA-2 compatibility 50
- VXAtape
  - See cartridges
- VXATool, using 31, 36

## W

- warranty
  - limited warranty terms 77
- weight of tape drive 52
- wet bulb, humidity specification
  - tape drive 56
  - VXAtape cartridge 61
- write and read specifications 50
- write reliability 51
- write-protect switch 22

## Notes